



CORTINA

Product Brief

Cortina Systems® CS2333 OC48 Integrated Quad MAC/Framer

Overview

The Cortina Systems® CS2333 is an integrated quad MAC / Framer (CS2333 MAC/Framer) combining POS, GFP, ATM and RPR functionalities with integrated four serial line interfaces (OC48 or OC12 or RPR over GE) for Router, Switch and MSPP applications.

Features

Quad STS-48 / STM-16 Processor supports

- Section, Line and Path processing, compliant with SONET/SDH standards (GR-253-CORE and G.707)
- DCC and APS processing and access to TOH/POH bytes via serial interfaces and microprocessor interface.
- Serial port for DCC or Transport Overhead
- Capability to insert and extract SONET/SDH overheads via the Overhead port
- Capability to insert and extract Section and Line DCC channels via the DCC port
- Extensive counter and alarm capabilities for management support

Mappers provided for

- GFP
- POS / X.85 (LAPS)
- ATM

RPR/SRP Processor

- IEEE 802.17* compliant
- Supports RPR over GFP, HDLC and GE
- External transit buffer
- SRAM Interface supports 2 to 16 Mbytes of external SRAM
- Supports single and dual transit buffer configurations
- Internal microsequencer handles fairness messages
- Support for all RPR priorities
- RPR processors can be bypassed
- Provide separate TP/Control messages buffer
- Extensive performance monitoring counters
- Support for legacy SRP equipment

Selective Power-Down

- In framer only mode all RPR MACs are powered down and the CS2333 MAC/Framer can be configured as:
 - Quad OC48 POS/GFP/ATM
 - Dual OC48 POS/GFP/ATM (2 Framers are powered down)
 - Quad OC12 POS/GFP/ATM
 - Dual OC12 POS/GFP/ATM (2 Framers are powered down)
- In RPR mode the CS2333 MAC/Framer can be configured:
 - Quad RPR/SRP over GE
 - Quad OC48 RPR/SRP
 - Dual OC48 RPR/SRP (2 Framers and 2 Ring MACs are powered down)
 - Quad OC12 RPR/SRP
 - Dual OC12 RPR/SRP (2 Framers and 2 Ring MACs are powered down)

SPI-4.2 System Interface

- Compliant with OIF-SPI4-02.0
- Supports Store and Forward feature in the Egress side
- Supports static and dynamic alignment

Line Interfaces

- Four independent OC48 or OC12 or RPR over GE serial interfaces

Standard µp and JTAG Interface

- Motorola* and Intel* compatible

Package

- UPBGA 33x33mm²
- 1020 total balls
- Designed for high speed serial interface

Low Power

- .13 µm CMOS technology
- Power dissipation of 6.9 W
- Power supplies of 2.5 V and 1.2 V

CS2333 MAC/Framer Block Diagram

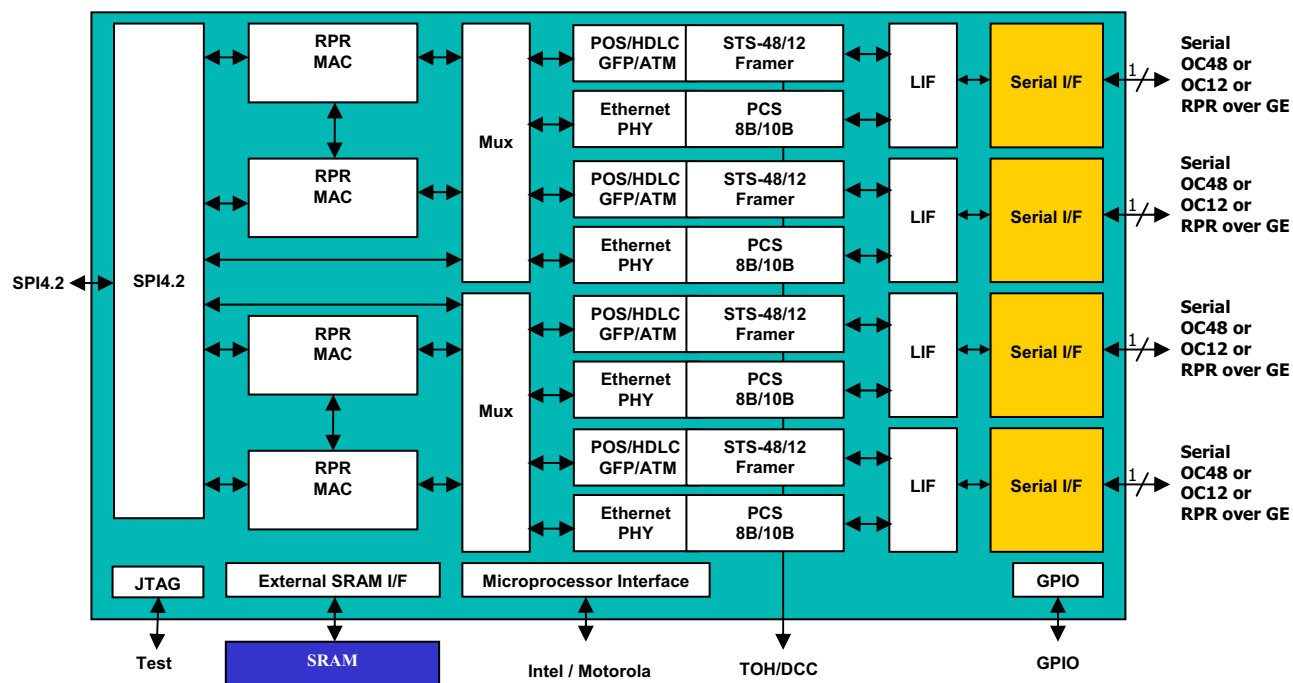

Router Line Card Application

Each of the ports can independently be configured to operate in RPR, SRP or point-to-point mode. The CS2333 MAC/Framer connects directly to SFP optical modules.

The port options here are RPR/SRP over GE / OC-48 / OC-12 and point-to-point over OC-48 / OC-12.

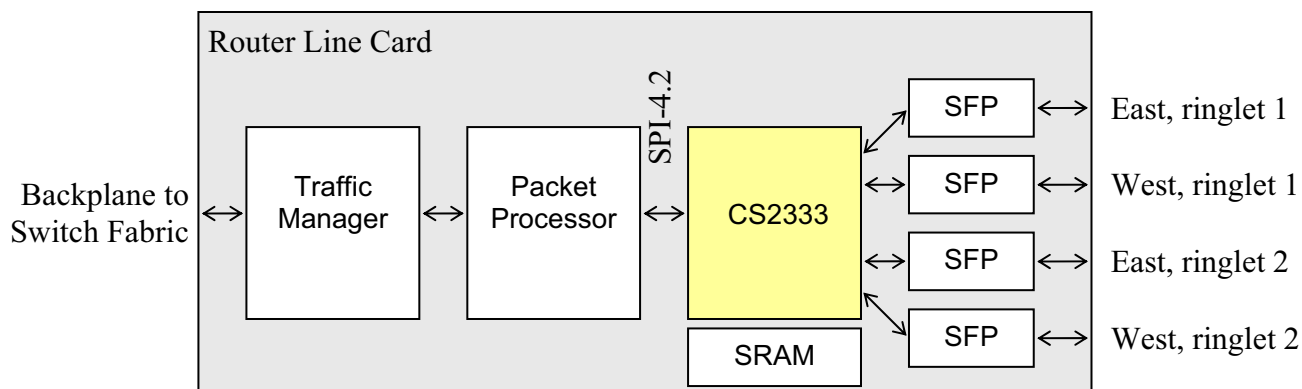

Router Line Card with 2.5 Gb/s Packet Processors

An FPGA translates between legacy SPI-3 and quarter rate SPI-4.2. The ports are GE/OC-12/OC-48. In OC-48 mode, two ports are used and the CS2333 MAC/Framer's SRAM ingress buffering is active to absorb large bursts of data to this node. For non-oversubscribed OC-48, dual 2.5 G packet processors are used.

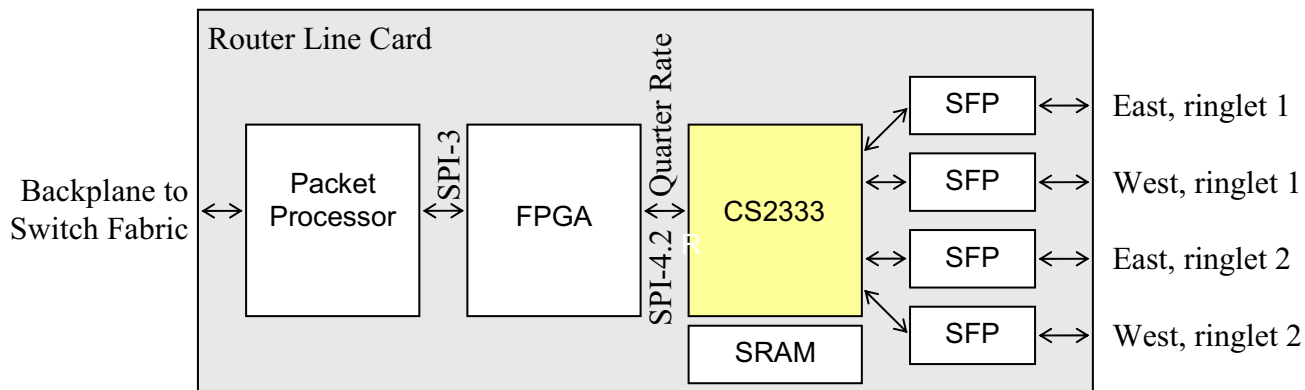

MSPP Line Card Application

Each of the ports can independently be configured to operate in RPR, SRP or point-to-point mode. The CS2333 MAC/Framer connects to the cross-connect through the backplane with 2.488 GHz / 622 MHz signals. Frames are aligned to an external 8kHz frame pulse.

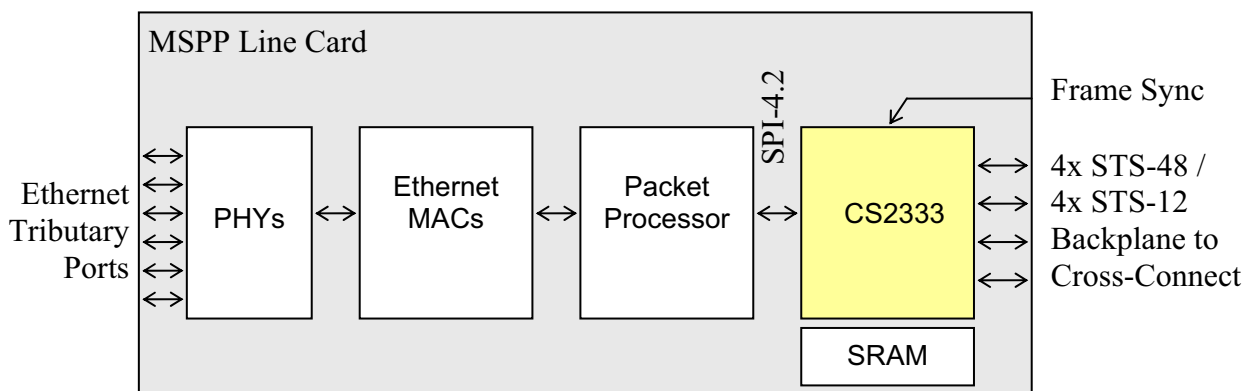

MSPP Line Card Application with Virtual Concatenation

The CS2333 MAC/Framer connects through its GE interfaces to an external EoS frames with virtual concatenation capability. Rate matching between the virtually concatenated channels and the CS2333 MAC/Framer is achieved using pause frames or side-band signals.

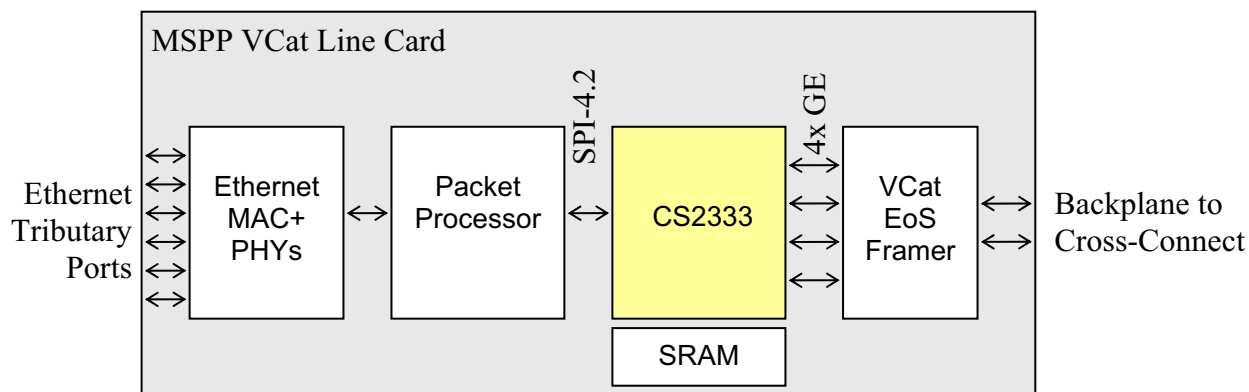

Cortina in Communications

Cortina is a leading supplier of intelligent communication solutions through continuous innovations in advanced port processing and intelligent port connectivity to the Core, Metro, Access and Enterprise Market Segments. With our state-of-the-art high speed analog digital integration, we deliver a wide suite of products that address our customers'

performance, density and flexibility needs enabling faster time-to-market, longer time-in-market, and increased revenue opportunities. Working closely with our customers to understand their system requirements and anticipate their needs, we are creating the foundation ingredients for new generations of services.

*Other names and brands may be claimed as the property of others.



Cortina Systems, Inc.
840 W California Ave.
Sunnyvale, CA 94086
408-481-2300
sales@cortina-systems.com
www.cortina-systems.com