

Marking Layout

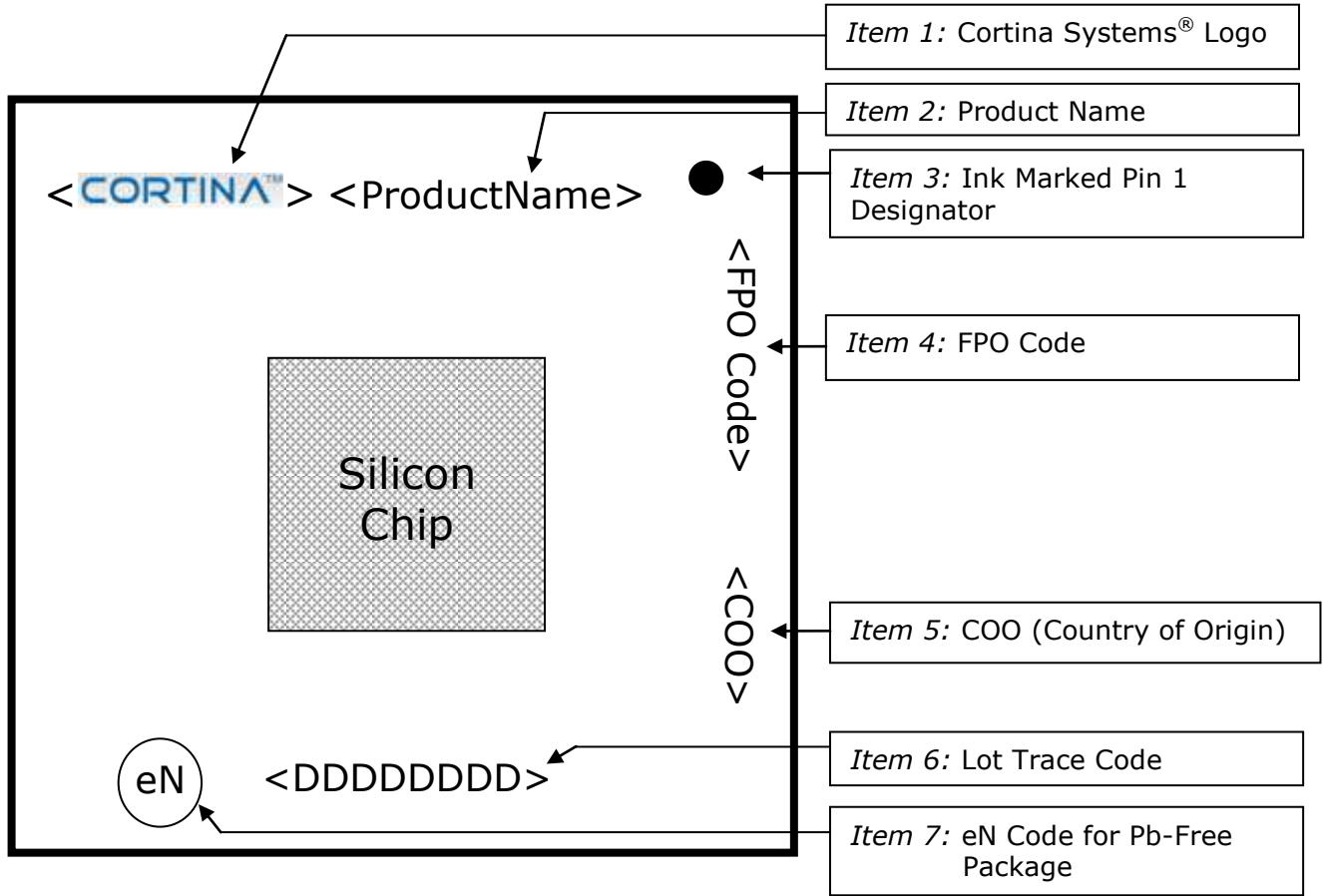

Photograph of Marked Device

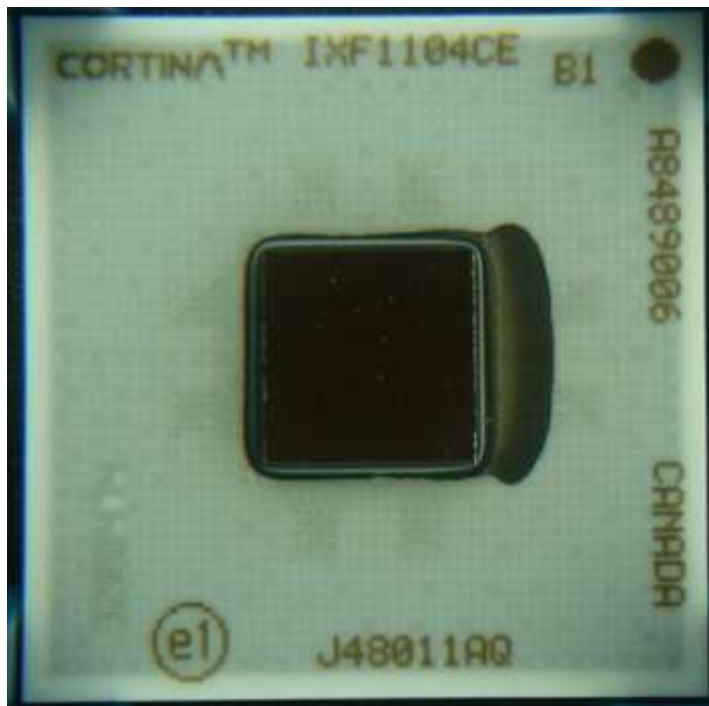

Marking Layout Description

Item #	Content	Fixed or Dynamic	Alignment	Font
1	Cortina Systems® Logo	Fixed	Top Left Corner	NA
2	Product Name	Fixed	Top Center	Veranda
3	Ink Marked Pin 1 Designator	Fixed	Top Right Corner	NA
4	FPO Code	Dynamic	Top Right Corner	Veranda
5	COO (Country of Origin)	Fixed	Bottom Right Corner	Veranda
6	Lot Trace Code	Fixed	Bottom Center	Veranda
7	eN Code for Pb-Free Package	Fixed	Bottom Left	Veranda

Product Naming Decoder

- WF** WF stands for RoHS compliance level and Lead-Free Package Designator (CBGA)
- WFIXF** IXF stands for the Product Prefix
- WFIXF1104** Product number is a 3-5 digit alphanumeric
- WFIXF1104C** Package indicator (not used on all products)
- WFIXF1104CE** Temperature indicator (commercial, extended)
- WFIXF1104CE B1** Product revision, xn=2 Alphanumeric character

* Device name may be truncated or alphanumeric characters left out intentionally on actual part marking due to lack of space and the need for legibility.

Product Order Number

WFIXF1104CE.B1-990726 The complete Cortina Systems ordering code includes this numeric 6 digit number. The MM# identifies the packing media (Tube, Tray, and Tape & Reel) from identical devices. Product revision changes are assigned new MM#. The MM# in not marked on the physical component but it appears on MBB, box and packing labels, packing slips, shipping documents, and invoices.

FPO Number & Date Code

- AYWW900A** Fixed header character for test subcontractor / location
- AYWW900A** Last digit of manufacturing year, Ex: Year 2009 = 9
- AYWW900A** Cortina workweek, first week of January = 01
- AYWW900A** Assembly house and location code
- AYWW900A** Sequential number that resets when WW is incremented: Refers to both sub-lots and wafer lots.

Lot Trace Code Cortina internal use

Author	Revision Content	Rev No.	Date
SY Fong	Initial Release	1.0	18 June 2009

INFORMATION IN THIS DOCUMENT IS PROVIDED IN CONNECTION WITH CORTINA SYSTEMS® PRODUCTS. NO LICENSE, EXPRESS OR IMPLIED, BY ESTOPPEL OR OTHERWISE, TO ANY INTELLECTUAL PROPERTY RIGHTS IS GRANTED BY THIS DOCUMENT. EXCEPT AS PROVIDED IN CORTINA'S TERMS AND CONDITIONS OF SALE OF SUCH PRODUCTS, CORTINA ASSUMES NO LIABILITY WHATSOEVER, AND CORTINA DISCLAIMS ANY EXPRESS OR IMPLIED WARRANTY RELATING TO THE SALE AND/OR USE OF CORTINA PRODUCTS, INCLUDING LIABILITY OR WARRANTIES RELATING TO FITNESS FOR A PARTICULAR PURPOSE, MERCHANTABILITY OR INFRINGEMENT OF ANY PATENT, COPYRIGHT OR OTHER INTELLECTUAL PROPERTY RIGHT.

Cortina products are not intended for use in medical, life saving, life sustaining, critical control or safety systems, or in nuclear facility applications.

CORTINA SYSTEMS®, CORTINA™, and the Cortina Earth Logo are trademarks or registered trademarks of Cortina Systems, Inc. or its subsidiaries in the US and other countries. Any other product and company names are the trademarks of their respective owners.

Copyright © 2009 Cortina Systems, Inc. All rights reserved.