



CORTINA

Product Brief

Cortina Systems® CS6001/2/3/4/5 Next Generation G.709 Optical Transport Processor Platform for 10G and 40G

Product Overview

Demand for bandwidth-intensive applications such as video-on-demand, music downloads, and telepresence is growing, and network delivery of larger file formats like HD video continues to gain in popularity. Telecom equipment makers are looking for solutions that allow them to deliver these bandwidth-intensive experiences to consumers while keeping their power usage and costs in check. The new Cortina Systems® CS600x Optical Transport Processor & FEC Device (CS600x Transport Processor) enables carriers to deliver high-quality, data-intensive services while reducing operational and capital expenditures by permitting efficient multiplexing and transparent transport of a broad spectrum of 10G class clients including Ethernet, SONET/SDH, and Storage over high speed optical transport networks as well as 40G.

The CS600x Transport Processor family offers advanced analog integration, proven optical transport networking, and FEC leadership. It aggregates and transports a broad mixture of 10G Ethernet, 10G-class storage, and SONET/SDH clients over 10G or 40G transport networks. Based on cutting-edge technology, the CS600x Transport Processor offers a rich feature set that allows for denser and more flexible line cards for metro and long-haul dense wavelength-division-multiplexing applications, Ethernet switch and router platforms, and submarine ultra long-haul systems. Key features include aggregation of four fully independent synchronous or asynchronous 10Gs tributaries to a 40G signal; super forward error correction ("Super FEC"); transport, mapping, and performance monitoring; and networking support for various client signals.

The CS600x Transport Processor family is offered as five different options that are specifically tailored to various 40G or 10G applications.

- The CS6001 Transport Processor features two 17-lane or 16-lane 40G-class interfaces (SFI-5.1 or 16-lane SFI-4.2), eight four-lane 10G-class interfaces (XAUI or SFI-4.2), and four XFI serial 10G-class interfaces. Additionally, each SFI-5.1 interface can be down-clocked to operate as a 16-bit SFI-4.1 compliant interface. The CS6001 Transport Processor can handle full duplex processing of either a single 40G signal or up to four independent 10G signals. The receiver and

transmit ports can be configured independently to monitor (and optionally terminate) OTU3/OC-768, 40GE, and OTU2/OC-192/10 GbE/FC-1200/FC-800 signals.

- The CS6002 Transport Processor is tailored for 40G Muxponder and Cross connect applications in the DWDM, and P-OTP platforms.
- The CS6003 Transport Processor is targeted for 4x10G applications in the DWDM, OTN-crossconnect applications.
- The CS6004 Transport Processor is targeted for 4x10G applications in the Router/Switch marketplace.
- The CS6005 Transport Processor is targeted for 2x10G applications.

The CS600x Transport Processor is compatible with Cortina devices, such as the Cortina Systems® CS2777, CS1222, CS3487, CS3477, and CS1999, on the client side.

Aggregation

The CS600x Transport Processor supports a variety of aggregation configurations. For example, the device can be used to aggregate 10G clients operating at different rates. Clients are independent - any mix of 10GE LAN PHY, 10G SDH/SONET, 10G OTN, or FC1200/800 is allowed. Conversely, an incoming aggregate 40G signal can be asynchronously de-aggregated to its original 10G clients. Additional possibilities include 24 x GbE Aggregation to dual 10G OTN for Long Haul WDM applications, NxGE aggregation, or demultiplexing 10G Class Signals from a 40G circuit backplane input.

10GE LAN Mapping

The CS600x Transport Processor supports many different methods, with varying degrees of transparency, to map and transport 10 GbE LAN clients over Transport Networks: by synchronously mapping the 10 GbE LAN client over an OPU2 or OPU1 payload (resulting in an OTU2 signal overclocked at 11.096 Gbps or 11.049 Gbps), by rate adapting the 64B/66B stream before mapping over OPU2 (or VC-4-64c) payload, or by using GFP-F encapsulation before mapping over OPU2 (or VC-4-64c).

Forward Error Correction

The 10G Super FEC scheme used in the CS600x Transport Processor is the Ultra-Strong FEC (UFEC) supported by the industry leading Cortina Systems® IXF30009/IXF30011 Optical Transport Processors and specified in section I.7 of the ITU G.975.1 recommendation. The device also supports a similar 40G Super FEC scheme according Section I.7 ("Ultra-Strong FEC") of the ITU G.975.1 recommendation. The device provides 10G & 40G configurable ultra-FECs with 4%, 7%, 10%, 15%, 20%, and 25% FEC overhead rates with a net coding gain of greater than 10 dB for Ultra Long Haul (ULH) and submarine applications. Standard G.709 (RS-255, 239) Forward Error Correction with a net coding gain of approximately 6 dB, allowing the CS6001 Transport Processor to be used as a single-chip G.709 FEC regenerator for 40 Gbps to 40 Gbps, quad 10 Gbps to/from 40 Gbps or dual 10 Gbps to dual 10 Gbps applications. FEC capabilities are supplemented with Advanced Error Rate Monitoring capabilities.

Features

The CS600x Transport Processor supports Core transport processing for various protocols:

- Full SONET/SDH TOH processing of OC-768 and OC-192 signals (termination and generation)
- Full G.709 compliant OxU2 and OxU3 overhead termination and generation
- Asynchronous aggregation of four independent 10G class signals into a standard or an over-clocked OTU3
- 10GE LAN/WAN, FC-1200, and FC800 non-intrusive Performance Monitoring
- Fully transparent and asynchronous mapping of one 40 Gbps or four 10 Gbps tributaries into an OTU3 or four independent OTU2s

Additional networking features supported include:

- Known pattern (PRBS, constant bit patterns) processing on all streams and layers
- Maintenance signal processing/propagation for SONET/SDH and OTN
- Reverse multiplexing (40 Gbps to/from 4x10 Gbps) for DWDM and cross-connect applications
- Substantial hardware support for G.709 and G.798 functions

High Speed Interfaces

- The CS600x Transport Processor has two sets of 17 x 3.5 Gbps-capable shared high-speed CML or LVDS configurable I/Os; each set could be configured for 40G or Nx10G (N=1,..,4) class line or client ports as:
 - 40G class SFI-5.1 compliant interface
 - 40G class 16-lane client agnostic backplane interface (extended SFI-4.2)
 - Four independent 10G class backplane or chip-to-chip interfaces with CML I/Os; each interface could be configured as a XAUI port or SFI-4.2 interface
 - Single 10G class 16-bit SFI-4.1 compliant parallel interface clocked at up to 800 MHz with LVDS I/O
- Four independent 10G class XFI serial interfaces clocked at up to 12.5 Gbps
- Optional DPSK, PSBT (ODB), or DQPSK differential pre-coders
- 16-bit general purpose microprocessor interface, Intel*-style and Motorola*-style, synchronous or asynchronous, interrupt driven or polling mode

Applications

- OTN networks
- FEC regenerators
- 10GE transport solution
- Protocol transparent transport
- Multiservice platforms
- SONET/SDH Add/Drop multiplexers
- Submarine and ULH FEC applications
- 10G/40G core and metro networks
- High density line cards for 10G networks (four bi-directional ports)
- 10GE LAN monitoring

Technology

- CS6001/2/3/5: 1517-ball BGA, 40x40 mm²
- CS6004: 896-ball BGA, 31x31 mm²
- 1.0 V (Core), 1.8 V (Analog), and 2.5 V (Digital I/Os) operational supplies
- CML, LVDS, and 2.5 V LVCMOS I/Os

CS600x Transport Processor Block Diagrams

Both the west side interface and east side interface feature the following connection: O_xU-3(V)/OC -768/40GE or 4XO_xU-2(V)/10GbE/OC-192/FC1200/800/400/200/100.

40G Regenerator / Transponder with Internal 40G SuperFEC

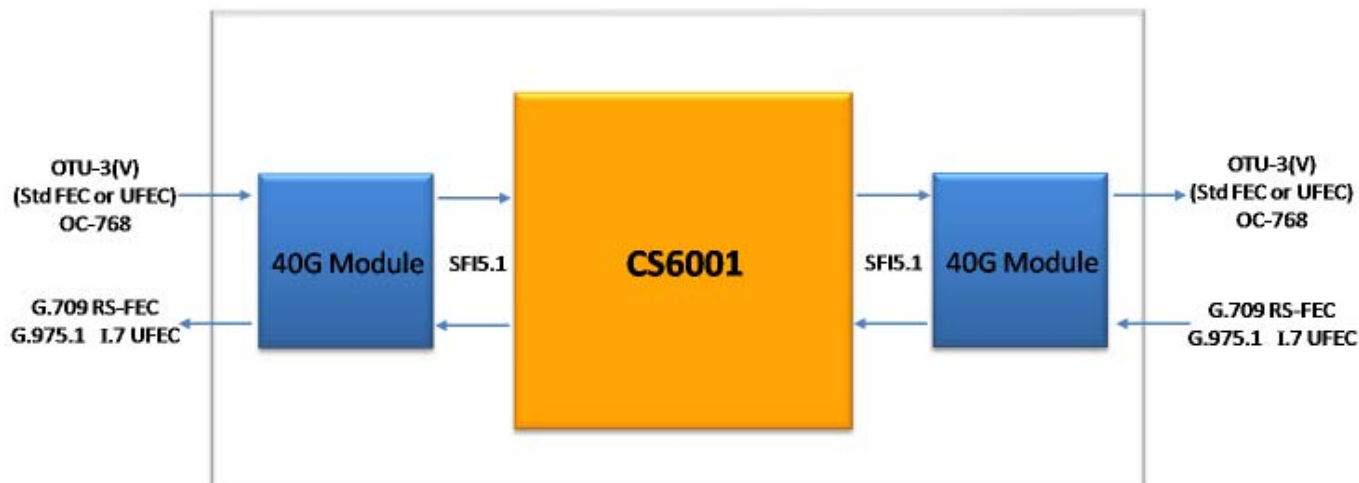

The CS600x Transport Processor shown below in either a transponder (SONET/SDH over OTU-3) or regenerator application. As the device integrates two 40G Ultra-FECs (G.975.1 I.7) and two 40G Standard FEC (G.709 RS-FEC) encoder/ decoders, both Ultra and/or Standard FECs can be used simultaneously on both 40G ports for regenerator or transponder applications.

Dual 10G Transponder

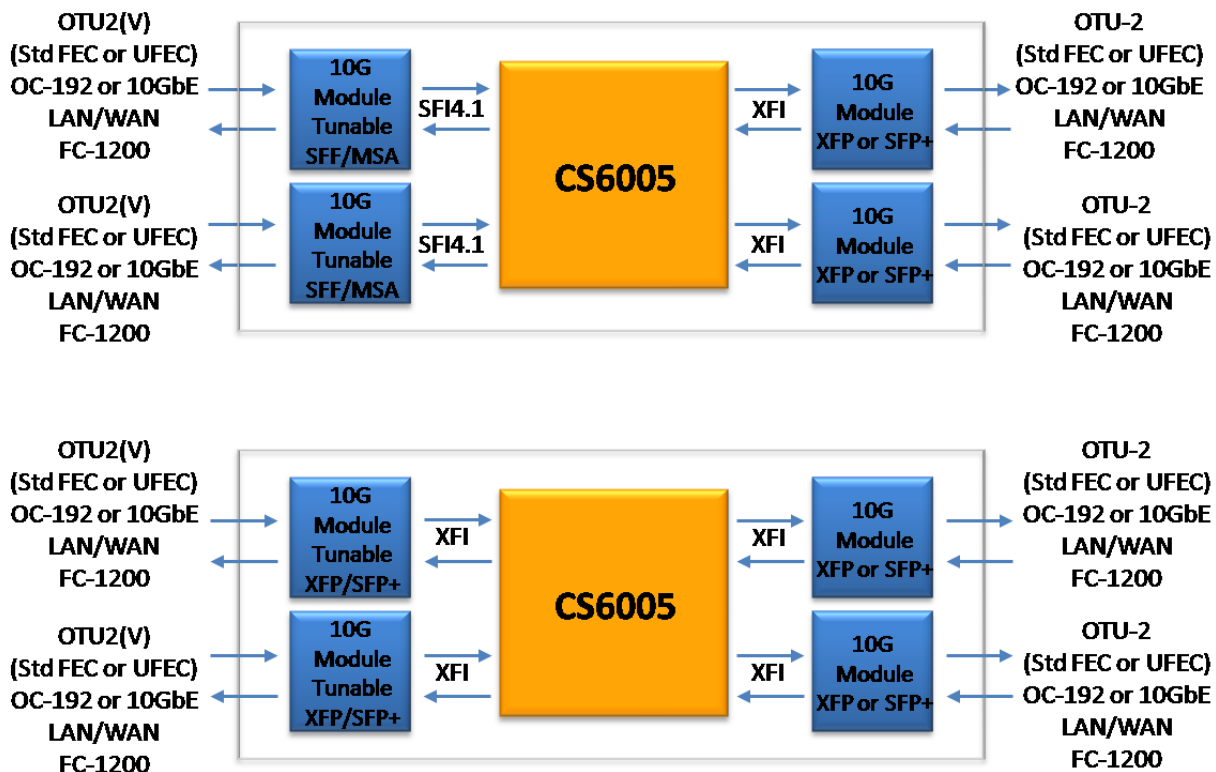

CS600x Transport Processor Block Diagrams (Con't)

This diagram illustrates the use of the CS600x Transport Processor in wrapping 10G client signals into an OTU-2 for transport with Ultra FEC. Note that the device supports both SFI4.1 and XFI interfaces. As the device integrates four 10G Ultra-FEC encoders/decoders and four 10G Std FEC encoders/decoders, both Ultra and/or Standard FECs can be used simultaneously on all four 10G ports.

2 x 10GE Aggregation (Oversubscription) And Transport Over Dual 10G OTN

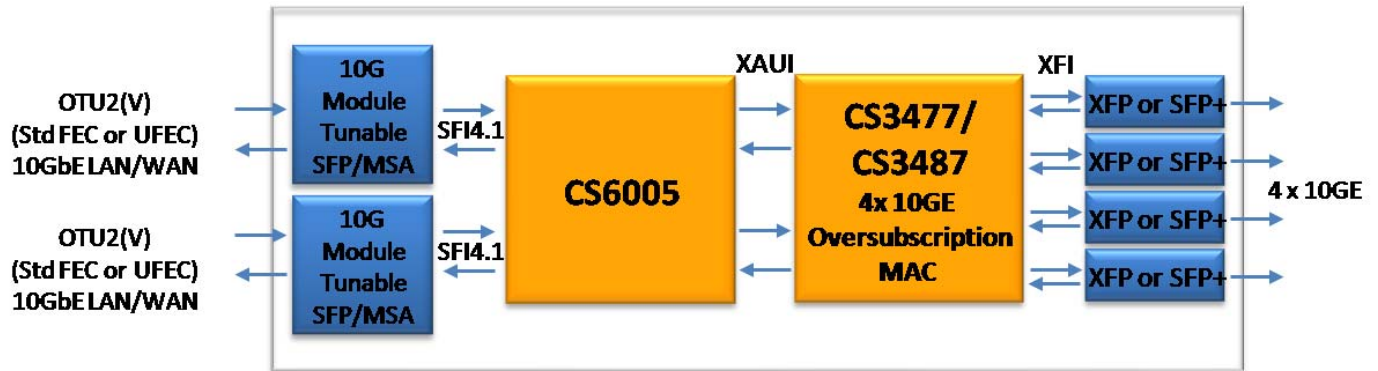

Cortina in Communications

Cortina is a leading supplier of intelligent communication solutions through continuous innovations in advanced port processing and intelligent port connectivity to the Core, Metro, Access and Enterprise Market Segments. With our state-of-the-art high speed analog digital integration, we deliver a wide suite of products that address our customers'

performance, density and flexibility needs enabling faster time-to-market, longer time-in-market, and increased revenue opportunities. Working closely with our customers to understand their system requirements and anticipate their needs, we are creating the foundation ingredients for new generations of services.

*Other names and brands may be claimed as the property of others.



Cortina Systems, Inc.
840 W California Ave.
Sunnyvale, CA 94086
408-481-2300
www.cortina-systems.com