

Marking Layout

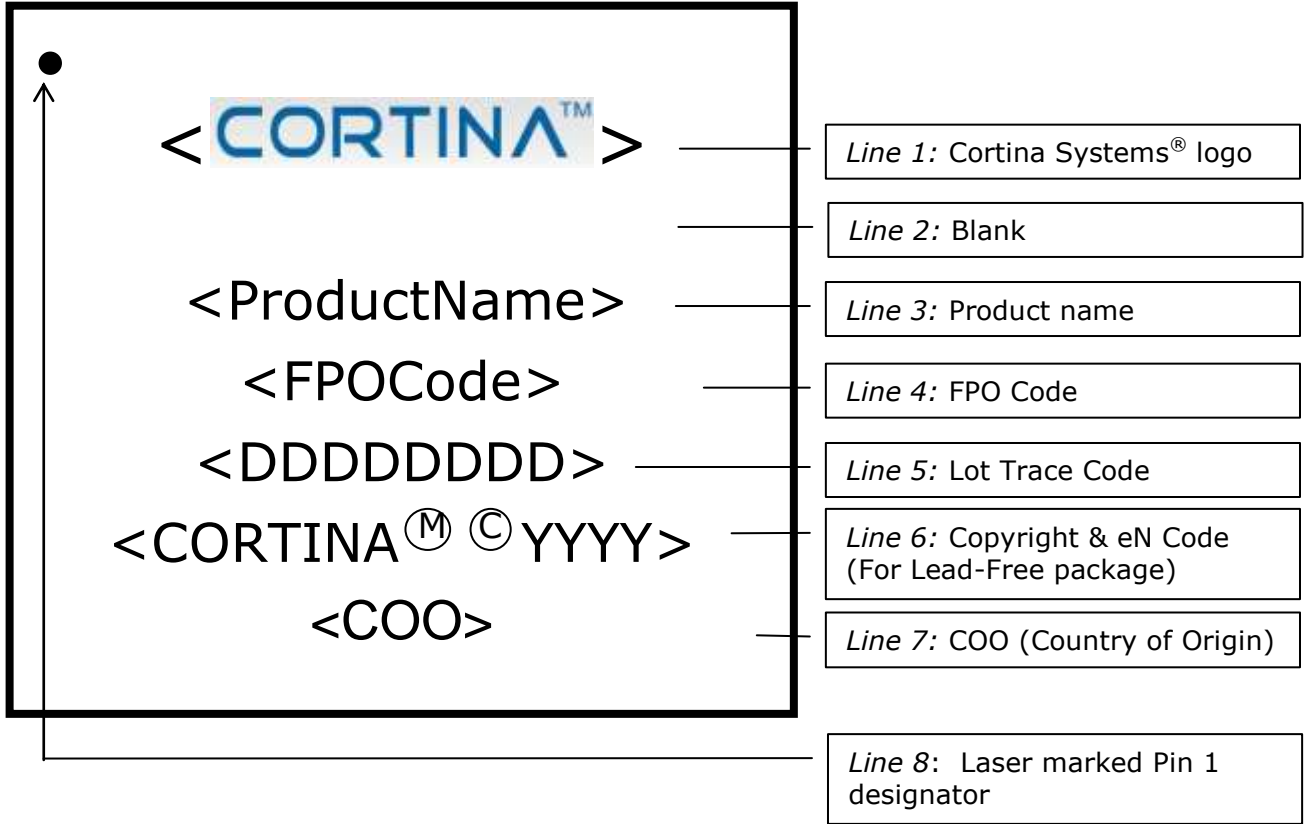

Photograph of Marked Device



Marking Layout Description

| Line # | Content | Fixed or Dynamic | Alignment | Font |
|--------|---|------------------|-----------|-------|
| 1 | Cortina Systems® logo | Fixed | Centered | NA |
| 2 | Reserved for Customer / Marketing | NA | NA | NA |
| 3 | Product Name | Fixed | Centered | Arial |
| 4 | FPO Code | Dynamic | Centered | Arial |
| 5 | Lot Trace Code | Dynamic | Centered | Arial |
| 6 | Copyright | Fixed | Left | Arial |
| 7 | COO (Country of Origin) & en (e1) as required | Fixed | Centered | Arial |
| 8 | Pin 1 Location marked by designator | Fixed | Left | NA |

Product Naming Decoder

- HP** HP Stands for RoHS compliance level and Package Designator (FCBGA)
- HPCS** CS stands for the Product Prefix
- HPCS2777** Product number is a 3-5 digit alphanumeric
- HPCS2777C** Temperature indicator (commercial, extended)
- HPCS2777C E0** Product revision, xn=2 Alphanumeric character

* Device name may be truncated or alphanumeric characters left out intentionally on actual part marking due to lack of space and the need for legibility.

Product Order Number

CS2777.E The complete Cortina Systems ordering code includes this numeric 6 digit number. The MM# identifies the packing media (Tube, Tray, and Tape & Reel) from identical devices. Product revision changes are assigned new MM#. The MM# is not marked on the physical component but it appears on MBB, box and packing labels, packing slips, shipping documents, and invoices.

FPO Number & Date Code

- MYWWT00A** Fixed header character for test subcontractor / location
- MYWWT00A** Last digit of manufacturing year, Ex: Year 2009 = 9
- MYWWT00A** Cortina workweek, first week of January = 01
- MYWWT00A** Assembly house and location code
- MYWWT00A** Sequential number that resets when WW is incremented: Refers to both sub-lots and wafer lots.

Lot Trace Code Cortina Internal use.

| Author | Revision Content | Rev No. | Date |
|---------------|-------------------------|----------------|------------------|
| SY Fong | Initial Release | 1.0 | 24 February 2009 |

This document contains information proprietary to Cortina Systems, Inc. (Cortina™). Any use or disclosure, in whole or in part, of this information to any unauthorized party, for any purposes other than that for which it is provided is expressly prohibited except as authorized by Cortina in writing. Cortina reserves its rights to pursue both civil and criminal penalties for copying or disclosure of this material without authorization.

INFORMATION IN THIS DOCUMENT IS PROVIDED IN CONNECTION WITH CORTINA SYSTEMS® PRODUCTS. NO LICENSE, EXPRESS OR IMPLIED, BY ESTOPPEL OR OTHERWISE, TO ANY INTELLECTUAL PROPERTY RIGHTS IS GRANTED BY THIS DOCUMENT. EXCEPT AS PROVIDED IN CORTINA'S TERMS AND CONDITIONS OF SALE OF SUCH PRODUCTS, CORTINA ASSUMES NO LIABILITY WHATSOEVER, AND CORTINA DISCLAIMS ANY EXPRESS OR IMPLIED WARRANTY RELATING TO THE SALE AND/OR USE OF CORTINA PRODUCTS, INCLUDING LIABILITY OR WARRANTIES RELATING TO FITNESS FOR A PARTICULAR PURPOSE, MERCHANTABILITY OR INFRINGEMENT OF ANY PATENT, COPYRIGHT OR OTHER INTELLECTUAL PROPERTY RIGHT.

Cortina products are not intended for use in medical, life saving, life sustaining, critical control or safety systems, or in nuclear facility applications.

CORTINA SYSTEMS®, CORTINA™, and the Cortina Earth Logo are trademarks or registered trademarks of Cortina Systems, Inc. or its subsidiaries in the US and other countries. Any other product and company names are the trademarks of their respective owners.

Copyright © 2009 Cortina Systems, Inc. All rights reserved.