

Marking Layout – COO Korea

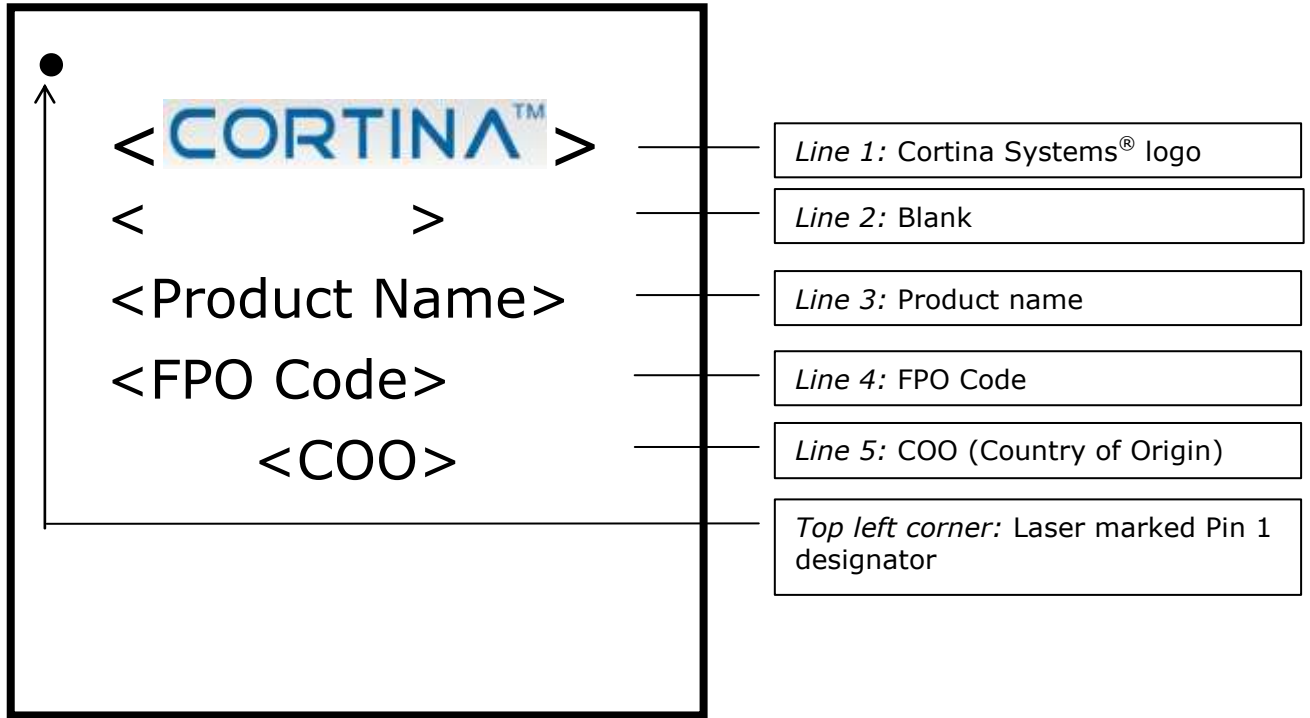

Photograph of Marked Device



Marking Layout Description

Line #	Content	Fixed or Dynamic	Alignment	Font
1	Cortina Systems® logo	Fixed	Left	NA
2	Reserved for Customer / Marketing	NA	NA	NA
3	Product Name*	Fixed	Left	Arial
4	FPO Code	Dynamic	Left	Arial
5	COO (Country of Origin)	Fixed	Center	Arial
	Pin 1 Location laser marked by designator	Fixed	Top left	NA

Product Naming Decoder

- FL** FL stands for RoHS compliance level and Package Designator (BGA)
- FLLXT** LXT stands for the Product Prefix
- FLLXT971** Product number is a 3 – 5 digits alphanumeric
- FLLXT971AB** Level One package indicator (not used on all products)
- FLLXT971ABC** Temperature indicator (commercial, extended)
- FLLXT971ABC A4** Product revision  $xn = 4$ , alphanumeric characters

\* Device name may be truncated or alphanumeric characters left out intentionally on actual part marking due to lack of space and the need for legibility. Characters (**FL**) omitted.

Product Order Number

- FLLXT971ABC.A4 – 834103**
  - FLLXT971ABC.A4 – 834926**
- The complete Cortina Systems ordering code includes this numeric 6 digits number. The MM# identifies the packing media (Tube, Tray, and Tape & Reel) from identical devices. Product revision changes are assigned new MM#. The MM# in not marked on the physical component but it appears on box and packing labels, packing slips, shipping documents, and invoices.

FPO Number & Date Code

- CYWWL00A** Fixed header character for test subcontractor / location
- CYWWL00A** Last digit of manufacturing year, Ex: Year 2009 = 9
- CYWWL00A** Cortina workweek, first week of January = 01
- CYWWL00A** Assembly house and location code
- CYWWL00A** Sequential number that resets when WW is incremented: Refers to both sub-lots and wafer lots.

Marking Layout – COO Malaysia

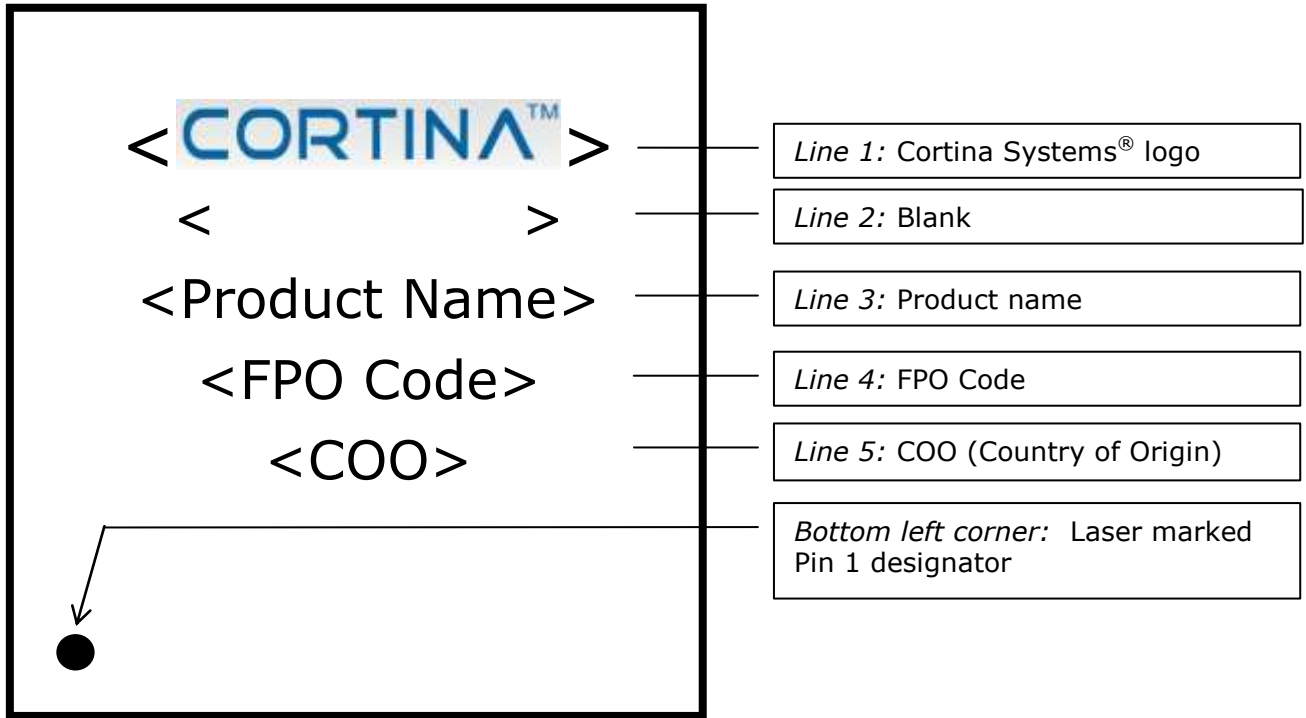

Photograph of Marked Device



Marking Layout Description

Line #	Content	Fixed or Dynamic	Alignment	Font
1	Cortina Systems® logo	Fixed	Center	NA
2	Reserved for Customer / Marketing	NA	NA	NA
3	Product Name*	Fixed	Center	Arial
4	FPO Code	Dynamic	Center	Arial
5	COO (Country of Origin)	Fixed	Center	Arial
	Pin 1 Location laser marked by designator	Fixed	Bottom left	NA

Product Naming Decoder

- FL** FL stands for RoHS compliance level and Package Designator (BGA)
- FLLXT** LXT stands for the Product Prefix
- FLLXT971** Product number is a 3 – 5 digits alphanumeric
- FLLXT971AB** Level One package indicator (not used on all products)
- FLLXT971ABC** Temperature indicator (commercial, extended)
- FLLXT971ABC A4** Product revision  $xn = 4$ , alphanumeric characters

\* Device name may be truncated or alphanumeric characters left out intentionally on actual part marking due to lack of space and the need for legibility.

Product Order Number

- FLLXT971ABC.A4 – 834103**
  - FLLXT971ABC.A4 – 834926**
- The complete Cortina Systems ordering code includes this numeric 6 digits number. The MM# identifies the packing media (Tube, Tray, and Tape & Reel) from identical devices. Product revision changes are assigned new MM#. The MM# is not marked on the physical component but it appears on box and packing labels, packing slips, shipping documents, and invoices.

FPO Number & Date Code

- CY**WWD00A Fixed header character for test subcontractor / location
- C**Y**WWD00A Last digit of manufacturing year, Ex: Year 2009 = 9
- CY**WW**D00A Cortina workweek, first week of January = 01
- CYWW**D**00A Assembly house and location code
- CYWWD**00A** Sequential number that resets when WW is incremented:  
Refers to both sub-lots and wafer lots.

<b>Author</b>	<b>Revision Content</b>	<b>Rev No.</b>	<b>Date</b>
Sivananda	Initial release	1.0	20 March 2009

**INFORMATION IN THIS DOCUMENT IS PROVIDED IN CONNECTION WITH CORTINA SYSTEMS® PRODUCTS. NO LICENSE, EXPRESS OR IMPLIED, BY ESTOPPEL OR OTHERWISE, TO ANY INTELLECTUAL PROPERTY RIGHTS IS GRANTED BY THIS DOCUMENT. EXCEPT AS PROVIDED IN CORTINA'S TERMS AND CONDITIONS OF SALE OF SUCH PRODUCTS, CORTINA ASSUMES NO LIABILITY WHATSOEVER, AND CORTINA DISCLAIMS ANY EXPRESS OR IMPLIED WARRANTY RELATING TO THE SALE AND/OR USE OF CORTINA PRODUCTS, INCLUDING LIABILITY OR WARRANTIES RELATING TO FITNESS FOR A PARTICULAR PURPOSE, MERCHANTABILITY OR INFRINGEMENT OF ANY PATENT, COPYRIGHT OR OTHER INTELLECTUAL PROPERTY RIGHT.**

Cortina products are not intended for use in medical, life saving, life sustaining, critical control or safety systems, or in nuclear facility applications.

CORTINA SYSTEMS®, CORTINA™, and the Cortina Earth Logo are trademarks or registered trademarks of Cortina Systems, Inc. or its subsidiaries in the US and other countries. Any other product and company names are the trademarks of their respective owners.

Copyright © 2009 Cortina Systems, Inc. All rights reserved.