



# CORTINA

## Product Brief

### Cortina Systems® CS3512 Single CPU Gigabit Ethernet Network Processor

#### Product Description

The Cortina Systems® CS3512 Single CPU Gigabit Ethernet Network Processor (CS3512 Network Processor) provides superior performance and functionality for Router Gateway, NAS, IP Set Top Box, VoIP, and other SME and SOHO applications.

The hardware crypto engine in the CS3512 Network Processor allows data encryption on network storage, DRM for multimedia IP protection, and VPN to run at full wire speed.

The embedded dual 10/100/1000 MACs allow system integrators the flexibility of configuring a traditional NAS server system with a one or two channel 10/100/1000 Ethernet PHY, or a NAS server plus router gateway capabilities with one WAN port and one LAN port.

The complete hardware acceleration engine improves the overall throughput in TCP/IP/UDP transmit, receive, and SAMBA read and write operations without the intervention of the CPU.

The dual USB 2.0 can be configured as host or client, which allows maximum flexibility in peripheral device integration, such as flash memory, USB control device, and USB 2.0 hard drives.

The PCI bus supports four master devices. The system integrator can add MPEG encoder, decoder, WiFi 802.11a/b/g/n access point or client functions, and other devices to deliver a complete wireless IP Set Top Box or Media Server product.

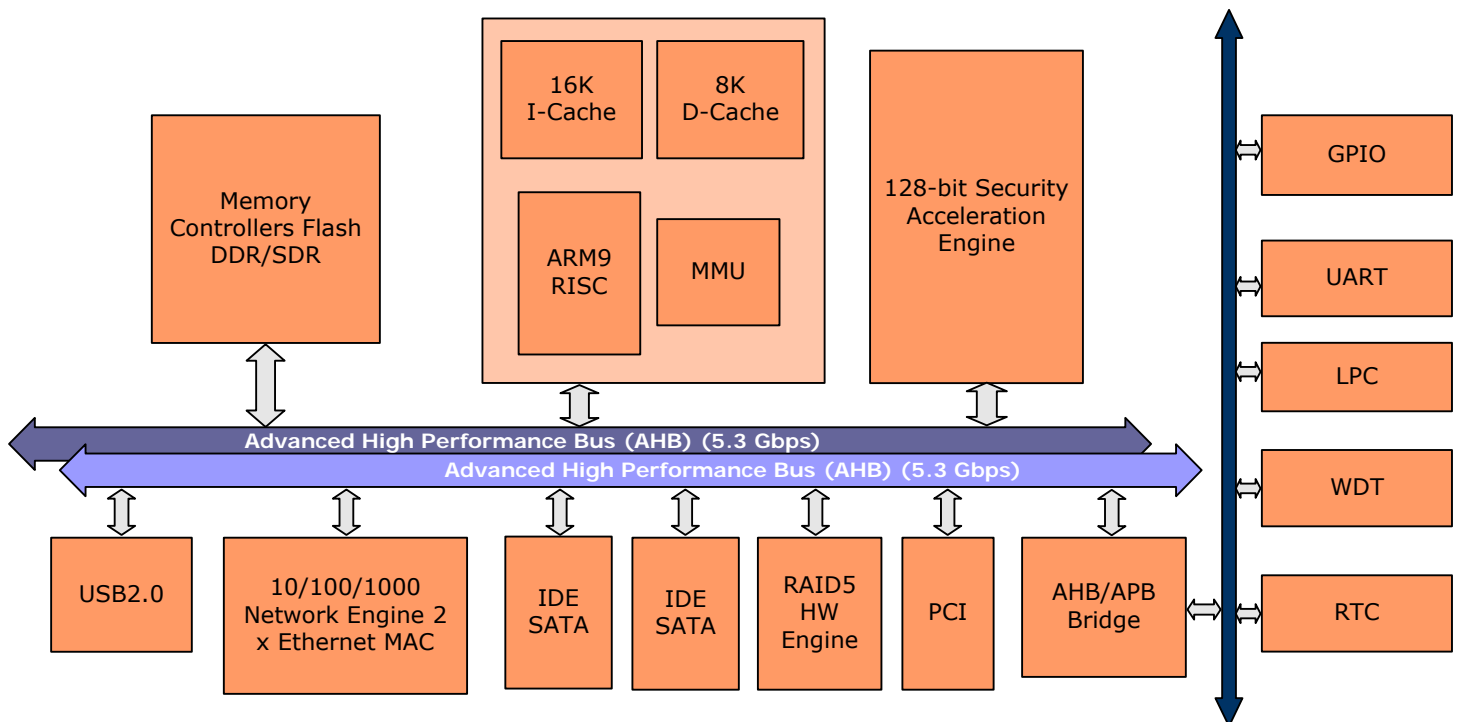

#### CS3512 Network Processor Block Diagram

## Features

- Single 32-bit 400 MIPS ARM9 RISC processor with separate embedded MMU and 8 K/16 K data/instruction cache
- Dual AHB with aggregate peak performance of greater than 10.6 Gbps for wire-speed operation
- Supports unlimited serial NAND flash
- Cortina proprietary buffer pre-fetch DDR controller
- Supports up to 256 MByte 16-bit 333 MHz (PC2700) external DDR SDRAM
- Supports single Ultra-133 IDE or dual SATA
- Hardware XOR RAID engine to support RAID5
- Dual USB 2.0 selectable host or slave
- Dual 802.3 compliant Ethernet MACs with 10/100 MII and 10/100/1000 RGMII
- Layer 2/3/4 hardware switching, routing, and NAT with 4 transmit queues per port for QoS support
- Layer 2-7 packet classification into 16 receive queues
- Transmit acceleration by TCP segmentation, IP fragmentation, and TCP/IP/UDP checksum calculation
- Receive acceleration by TCP connection table lookup, assembly of multiple packets belonging to the same TCP connection, and TC/IP/UDP checksum verification
- Hardware Security Acceleration Engine performs DES, 3DES, AES, CCMP, and RC4 encryption/decryption with CBC or ECB mode operation; authentication with SHA1, MD5, HMAC-SHA1, and HMAC-MD5 hashing algorithm
- Hardware 32-bit true random number generator
- 32-bit PCI 2.2 bus interface up to 66 MHz with four master device support
- Supports CCIR/ITU-601/656 component video interface (YPbPr) for up to 640\*480 VGA quality image
- Intelligent and programmable power management
- Timer, GPIO, UART, Watch Dog Timer
- Embedded Real Time Clock for true server applications
- Integrated OSC/PLL circuits require single 60 MHz crystal
- 0.13  $\mu$ m standard CMOS with approximately 1.5 W dissipation
- Low cost and small foot print 324-pin FBGA

## Benefits and Applications

- Configurable external memory interfaces provide system integrators maximum flexibility to achieve best price performance ratio
- Integrated SATA interfaces provides significant performance gain and cost reduction compared to discrete IDE and SATA bridge devices
- Dual USB 2.0 to support versatile peripheral device interface and storage extension
- Dual Ethernet MACs enables high availability system design or superior WAN to LAN throughput
- Up to 2 Gbps full duplex Layer 2 switching
- Up to 1 Gbps NAT throughput
- Programmable QoS handling with 4 transmit queues and 16 receive queues enables priority management and processing of different types of traffic
- TCP/IP/UDP processing assisted by a proprietary hardware acceleration engine significantly improves overall network and file transfer throughput
- The built-in hardware security accelerator engine enables significant performance improvement in VPN tunneling, IPSec, and secure file transfers by processing packet encryption, decryption, hashing, and authentication functions in hardware

## Benefits and Applications Continued

- Print Server software with the selectable USB port and the LPC interface allows quick and inexpensive addition of a network printer
- Comprehensive peripheral device interfaces such as UART and GPIO allow maximum flexibility in LCD, LED, and other slave device programming
- Embedded Real Time Clock enables easy system management
- PCI bus interface to support external peripheral components such as 802.11a/g/n modules and MPEG codec
- Intelligent and programmable power management control module supports full power, idle, standby, and shut-down mode to enable power sensitive designs such as hand-held and mobile applications
- Internal multi-PLL circuits simplify designs and requires a simple crystal (60 MHz) which reduces overall system cost

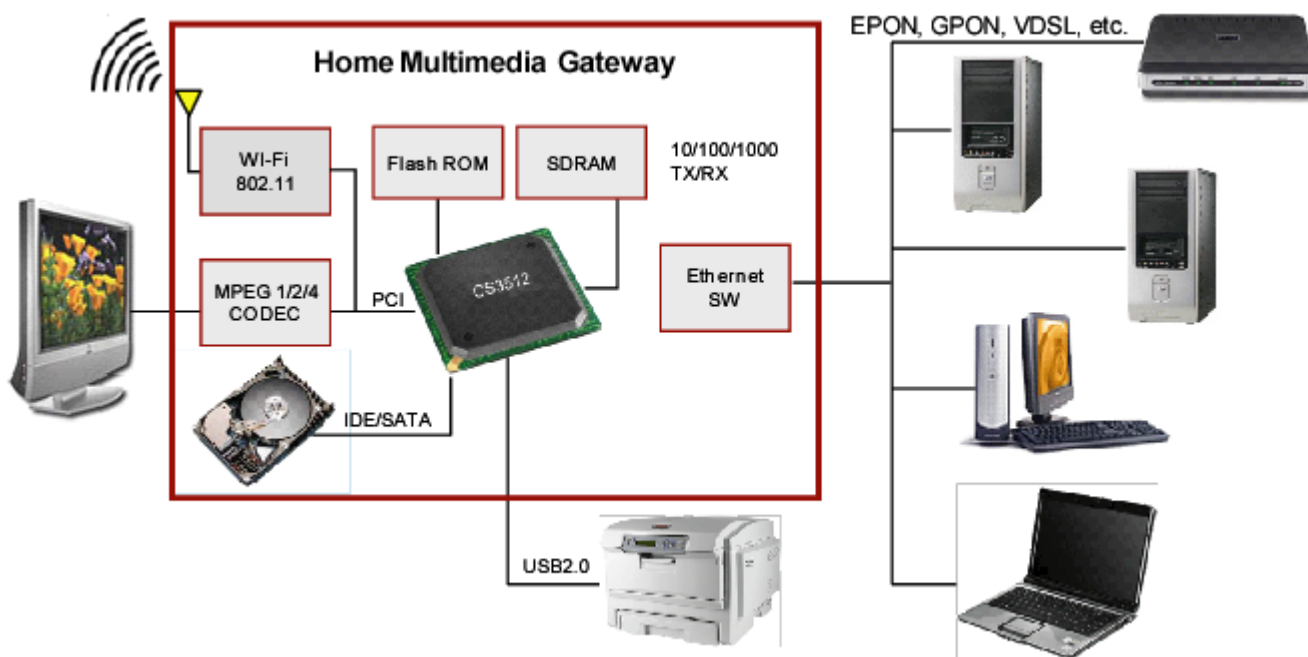

## Cortina in Communications

Cortina is a leading supplier of intelligent communication solutions through continuous innovations in advanced port processing and intelligent port connectivity to the Core, Metro, Access and Enterprise Market Segments. With our state-of-the-art high speed analog digital integration, we deliver a wide suite of products that address our customers'

performance, density and flexibility needs enabling faster time-to-market, longer time-in-market, and increased revenue opportunities. Working closely with our customers to understand their system requirements and anticipate their needs, we are creating the foundation ingredients for new generations of services.

\*Other names and brands may be claimed as the property of others.



Cortina Systems, Inc.  
840 W California Ave.  
Sunnyvale, CA 94086  
408-481-2300  
sales@cortina-systems.com  
www.cortina-systems.com