



TM

CORTINA

Product Brief

Cortina Systems® CS8016 EPON Optical Network Unit Chip

Overview

The Cortina Systems® CS8016 Gigabit Ethernet Passive Optical Network (GEAPON or EPON) Optical Network Unit (ONU) chip (CS8016 ONU) implements functions for Customer Premise Equipment (CPE). Equipment vendors can build a complete CPE box with the CS8016 ONU and add extra features using the embedded CPU, spare Flash memory space, external SRAM interface, and flexible GPIO bus.

The CS8016 ONU is an IEEE 802.3ah* standard-compliant device. It allows equipment vendors and network operators to build an EPON system mixing and matching with different IEEE 802.3ah* compliant devices. The standard-compliant solution enables network operators to preserve their investment and save their cost in the long run.

The CS8016 ONU works in conjunction with the Cortina Systems® CS8021 Optical Line Terminal (OLT) (CS8021 OLT) and the Intelligent Real-Time Operating System (iROS). The iROS is a distributed and scalable operating system that runs on the CS8016 ONU, CS8021 OLT, and the system control plane to control

and manage the EPON system. This architecture provides a wide range of Quality-of-Service (QoS) and Traffic Management services. They ensure the bandwidth, delay, and jitter requirement for each ONU are met according to the traffic profile extracted from the Service Level Agreement (SLA).

The CS8021 OLT and CS8016 ONU also provide differentiated services for various categories of traffic to ensure preferential treatment to high priority traffic such as voice and video. To meet these goals, the iROS traffic management feature-set provides APIs to configure five major QoS components in the CS8021 OLT and CS8016 ONU – Dynamic Bandwidth Allocation (DBA) algorithm, traffic classification, traffic conditioning (shaping, policing, and marking), queue scheduling, and buffer management. All these components work together to provide SLA-based QoS guarantees, fair allocation of excess bandwidth, and prioritization of user traffic across ONUs and OLTs in the EPON system, in both upstream and downstream directions.

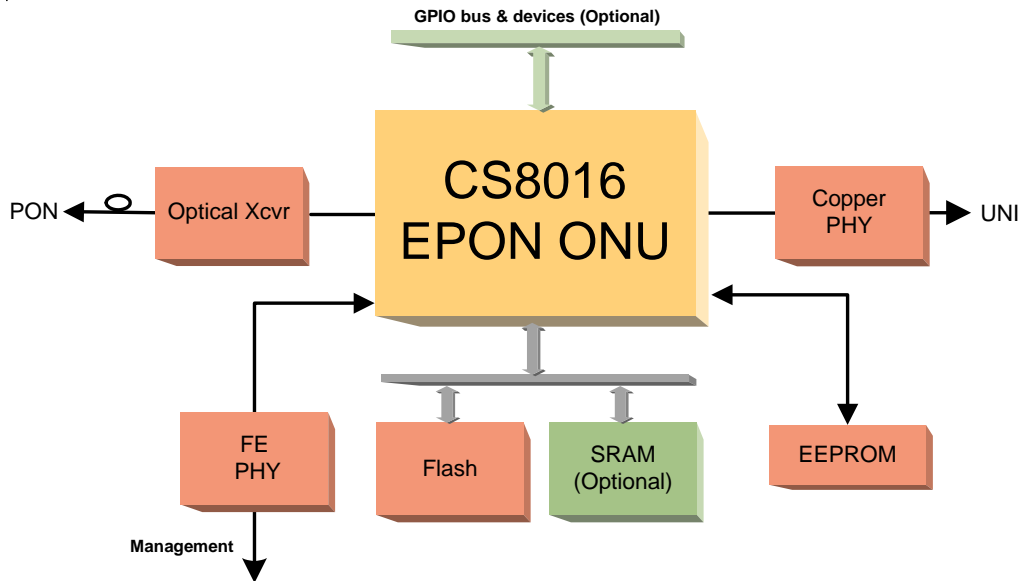

Typical System Application Diagram

Highlights

- Highly integrated low cost ONU solution
- IEEE 802.3ah* MPCP compliant
- IEEE 802.3ah* OAM supported
- Integrated 1.25 Gbps EPON SerDes
- Integrated IEEE 802.1D* specified bridging functions
- Traffic classification, scheduling, and buffer management
- IEEE 802.1ad* supported; Q-in-Q VLAN tagging
- User Network Interface (UNI) port bridge filtering
- AES and Churning Security Algorithms
- Embedded frame buffer memory
- IEEE 802.3x* flow control and backpressure on UNI interface
- Efficient IP multicast support
- Wire-speed Forward Error Correction (FEC) in both downstream and upstream
- Built-in ARM-9 microprocessor for management and control
- Interfaces supported
 - Interface for the UNI port
 - Interface for the PON port
 - Interface for the management port
 - Flash/SRAM interface
- JTAG support for ease of system manufacturing
- Low power CMOS design with 5 V tolerant I/O
- In compliance with China Telecom EPON Technical Specification

Feature Details

EPON Protocol

- Implements standard-compliant Ethernet Multi-point MAC control functions specified in IEEE 802.3ah*
- Supports point-to-point emulation between each ONU and OLT using Logical Link Identifier (LLID)
- Supports complete processing and generation of MPCP control messages
- Supports standard based as well as vendor-specific registration and deregistration

Ethernet OAM Management

- Implements complete IEEE 802.3ah* OAM functions
- Supports bridge/Ethernet MIBs
- Supports EFM MIB
- Supports EFM OAM MIB
- Supports remote ONU management
- OAM indication and alarm reporting

Bridging

- Implements layer-2 IEEE 802.1D* bridging function
- Supports address learning table
- Embeds on-chip frame buffer memory
- Supports UNI port filtering
- Supports IEEE 802.1ad* provider bridging function; Q-in-Q VLAN tagging

Multicast Management

- Implements IGMP snooping and multicast filtering
- Supports multicast group addresses per LLID

Security

- 802.1x authentication
- Encryption based on AES or churning
- Key exchange protocols

Feature Details Continued

Forward Error Correction

- Compliance with IEEE 802.3ah* standard
- Wire-speed operation in both downstream and upstream

Traffic Management

- Configurable QoS modes
- Support multiple priority class queues scheduling scheme
- Supports for IEEE 802.3x* flow control or backpressure on UNI port
- Traffic classification in the upstream direction
- Dynamic and efficient buffer management

Cortina in Communications

Cortina is a leading supplier of intelligent communication solutions through continuous innovations in advanced port processing and intelligent port connectivity to the Core, Metro, Access and Enterprise Market Segments. With our state-of-the-art high speed analog digital integration, we deliver a wide suite of products that address our customers' performance, density and

flexibility needs enabling faster time-to-market, longer time-in-market, and increased revenue opportunities. Working closely with our customers to understand their system requirements and anticipate their needs, we are creating the foundation ingredients for new generations of services.

*Other names and brands may be claimed as the property of others.



Cortina Systems, Inc.
840 W California Ave.
Sunnyvale, CA 94086
408-481-2300
sales@cortina-systems.com
www.cortina-systems.com