



CORTINA

Product Brief

Cortina Systems® CS3472 24-Port Gigabit Ethernet Line Rate MAC

Overview

The Cortina Systems® CS3472 24-port Gigabit Ethernet Line Rate MAC (CS3472 MAC), a member of the Cortina Systems, Inc. (Cortina™) Interlaken family, is the industry's first 24-port Gigabit Ethernet Line Rate MAC that doubles the line rate bandwidth of existing SPI based MACs enabling higher density Enterprise and Metro Ethernet switches and routers.

The CS3472 MAC integrates all SerDes, PHYs, MACs, classification and policing functions into a single device. All 24 ports can operate at both wire-speed and oversubscribed modes of operation.

In the oversubscribed modes, the CS3472 MAC offers extensive Quality of Service (QoS) for line cards through a combination of a deep packet classifier, 4 queues per ingress port, option for external packet buffer memory, and multiple scheduling modes.

The CS3472 MAC connects to a packet processor through the highly versatile Interlaken interface (up to 8 lanes and up to 6.25 Gbps per lane, and 24 channels mapped to 24 GbE ports) or through dual XA UI interfaces.

The device can operate in the following fundamental modes:

Line-rate:

- Host interface can sustain 24 Gbps bandwidth

Over-subscription using internal/external memory:

- Host interface can sustain lower than 24 Gbps bandwidth

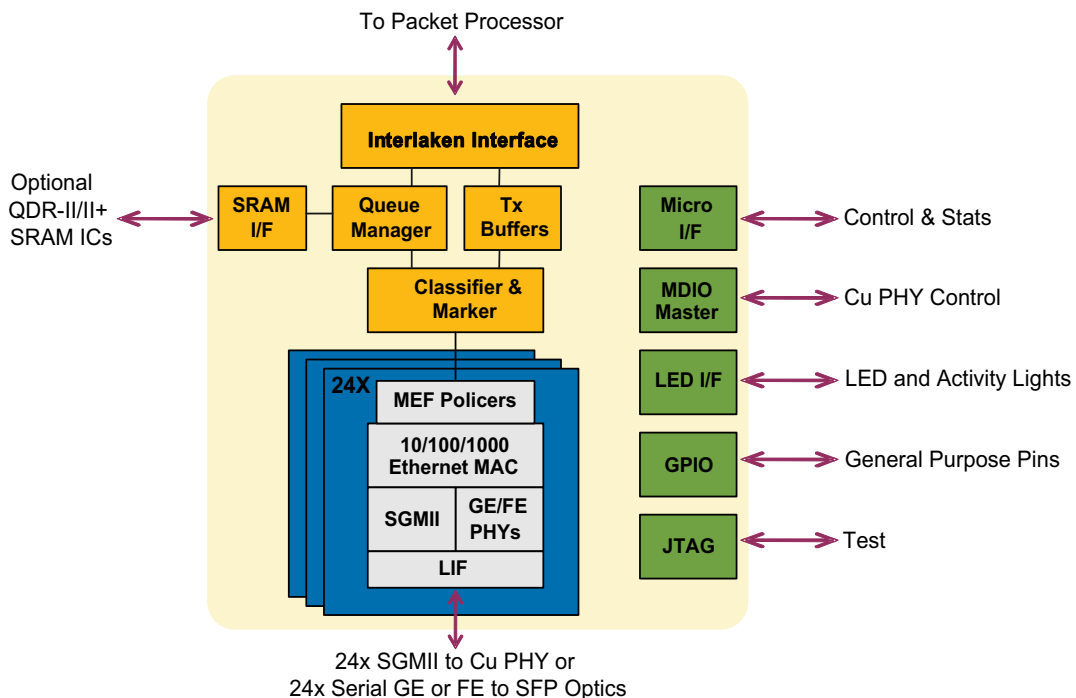

CS3472 MAC Block Diagram

Summary of Features and Benefits

Functionality:

- 24x 10/100/1000 Mbps Ethernet MACs
- A high-speed channelized Interlaken uplink
- Rule-based layer 5 classification engine with IPv6 support
- 24 port line rate operation
- Oversubscribed operation with four queues per ports
- Internal memory or external memory oversubscription
- Random Early Discard (RED) support
- Priority marking of DSCP and 802.1p fields
- Committed and burstable rates enforced
- MEF per-VLAN policing, statistics, and tagging
- Assign lower priority to excess frames
- Jumbo frame support
- Ethernet MIB and RMON
- Supports synchronous Ethernet timing distribution
- Partners with Cortina Systems® CS3477 to create a complete GE & 10 GE Interlaken solution
- Supports new Metro synchronization requirements
- Combines all SerDes, PHY, and MAC classification and policing functions into a single device reducing complexity and cost
- Offers a very high-density line-rate or oversubscription aggregation front-end solution
- Delivers extensive QoS for oversubscribed line cards through a combination of a deep packet classifier, 4 queues per ingress port, deep external oversubscription memories, and multiple scheduling modes
- Integrates a rule-based layer 5 classification and IPv6 support to meet QoS requirements
- Connects to the host through the Interlaken interface (a high-speed, channelized packet interface) or through two XAUI interfaces
- Integrates a JTAG interface that is IEEE 1149.1 compliant
- Supports store-and-forward mode and a low-latency cut-through mode independently in RX and TX directions
- Reduces board complexity through native connections to optical SFP modules and copper SGMII PHYs
- Integrates Clock and Data Recovery (CDR) removing the need for external clocking
- Contains ECC protected internal memories

Interfaces:

- 24x SGMII to 10/100/1000 Mbps Ethernet Copper PHYs
- 24x serial GE and FE (100BASE-FX) to optical SFP modules
- Number of lanes and bitrates for uplink is scalable
 - 5-lane Interlaken uplink at 6.25 Gbps bit rate; or
 - 8-lane Interlaken uplink at 4.25 Gbps bit rate
- 250 MHz QDR-II/II+ SRAM interface for optional oversubscription buffering
- Generic parallel microprocessor bus
- LED status port
- MDIO master port to control tri-speed copper PHYs
- JTAG and GPIO ports

Technology:

- 1152 ball, 35x35mm organic Ultra-Performance Ball Grid Array (UPBGA) package

Application: GE Switch/Router Front End - Line Rate

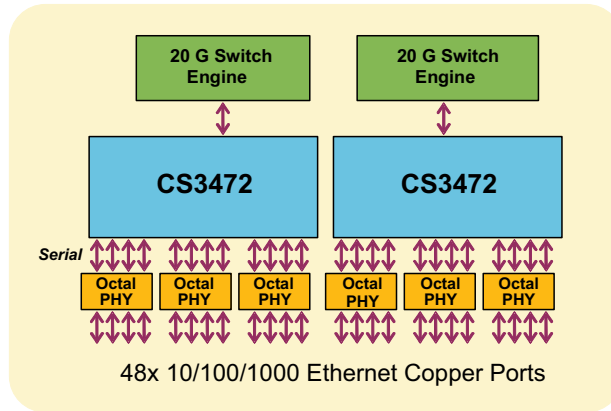

Serial SGMII connections to Copper PHYs allow use of new high-density PHYs and reduce board complexity. Direct connection to SFP optics is also supported.

Application: GE Switch/Router Front End - 2:1 Oversubscribed

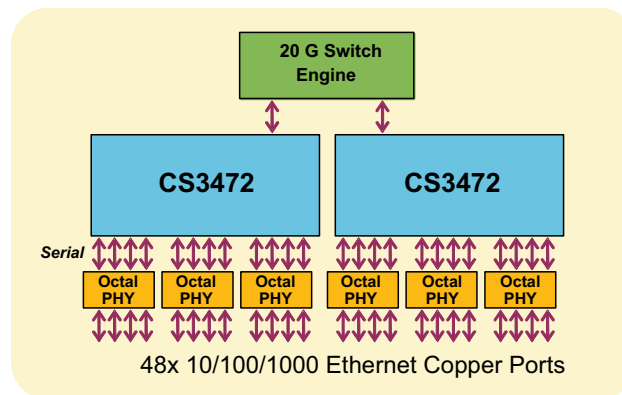

Cortina in Communications

Cortina is a leading supplier of intelligent communication solutions through continuous innovations in advanced port processing and intelligent port connectivity to the Core, Metro, Access and Enterprise Market Segments. With our state-of-the-art high speed analog digital integration, we deliver a wide suite of products that address our customers' performance, density and

flexibility needs enabling faster time-to-market, longer time-in-market, and increased revenue opportunities. Working closely with our customers to understand their system requirements and anticipate their needs, we are creating the foundation ingredients for new generations of services.

*Other names and brands may be claimed as the property of others.

