



Cortina Systems[®] LXT384/6/8 Twisted Pair Interface—Without Component Changes

Application Note

8 September 2007

Document Number 249138

Revision 2.0

INFORMATION IN THIS DOCUMENT IS PROVIDED IN CONNECTION WITH CORTINA SYSTEMS® PRODUCTS. NO LICENSE, EXPRESS OR IMPLIED, BY ESTOPPEL OR OTHERWISE, TO ANY INTELLECTUAL PROPERTY RIGHTS IS GRANTED BY THIS DOCUMENT.

EXCEPT AS PROVIDED IN CORTINA'S TERMS AND CONDITIONS OF SALE OF SUCH PRODUCTS, CORTINA ASSUMES NO LIABILITY WHATSOEVER, AND CORTINA DISCLAIMS ANY EXPRESS OR IMPLIED WARRANTY RELATING TO THE SALE AND/OR USE OF CORTINA PRODUCTS, INCLUDING LIABILITY OR WARRANTIES RELATING TO FITNESS FOR A PARTICULAR PURPOSE, MERCHANTABILITY OR INFRINGEMENT OF ANY PATENT, COPYRIGHT OR OTHER INTELLECTUAL PROPERTY RIGHT.

Cortina products are not intended for use in medical, life saving, life sustaining, critical control or safety systems, or in nuclear facility applications.

Cortina Systems® and the Cortina Systems logo are the trademarks or registered trademarks of Cortina Systems, Inc. and its subsidiaries in the U.S. and other countries. Other names and brands may be claimed as the property of others.

Copyright © 2001–2007 Cortina Systems, Inc. All rights reserved.

Contents

1.0	General Description	5
2.0	LXT384/6/8 T1/E1 LIU Family	6
3.0	Standard Line Interface Circuitry	7
4.0	Universal T1/E1 Interface	8
4.1	Transmit Interface	8
4.1.1	High Transmit Return Loss Interface	8
4.2	Transmit Interface Summary	15
4.2.1	Receive Interface	15
5.0	Conclusions	18

Figures

1	LXT384/6/8 T1/E1 LIU Circuitry	5
2	High Tx Return Loss Interface	8
3	E1, Twisted Pair Cable Output	9
4	E1 Twisted Pair, Tx Return Loss	9
5	Low Power Interface	10
6	E1, Twisted Pair Cable Output	10
7	T1, LEN = 011 @ 0 ft. Cable	11
8	T1, LEN = 011 @ 131 ft. Cable	11
9	T1, LEN = 100 @ 131 ft. Cable	11
10	T1, LEN = 100 @ 262 ft. Cable	12
11	T1, LEN = 101 @ 262 ft. Cable	12
12	T1, LEN = 101 @ 393 ft. Cable	12
13	T1, LEN = 110 @ 393 ft. Cable	13
14	T1, LEN = 110 @ 524 ft. Cable	13
15	T1, LEN = 111 @ 524 ft. Cable	13
16	T1, LEN = 111 @ 655 ft. Cable	14
17	T1 Twisted Pair, Tx Return Loss	14
18	E1 Twisted Pair, Tx Return Loss	15
19	T1/E1 Receive Interface	16
20	E1 Twisted Pair, Tx Return Loss	16

Tables

1	Transmit Interface Performance Summary	17
---	--	----



Revision History

Revision 2.0 Revision Date: 8 September 2007
First release of this document from Cortina Systems, Inc.
Revision 001 Revision Date: January 2001
Initial release.

1.0 General Description

In today's global economy, a critical consideration when designing telecommunications systems is compatibility with the various international standards. Ideally, one should be able to design a system that can be sold in the different international markets with minimal or no hardware changes. By doing so, the manufacturer reduces the cost associated with maintaining different system versions. The designer of T1/E1 line interfaces is often faced with this same challenge. Meeting all the electrical specifications using the same line interface circuitry for T1 and E1 can be a difficult task. This Application Note proposes two universal T1/E1 twisted pair line interface solutions using Cortina Systems® 3.3 V T1/E1 LIUs.

Figure 1 LXT384/6/8 T1/E1 LIU Circuitry

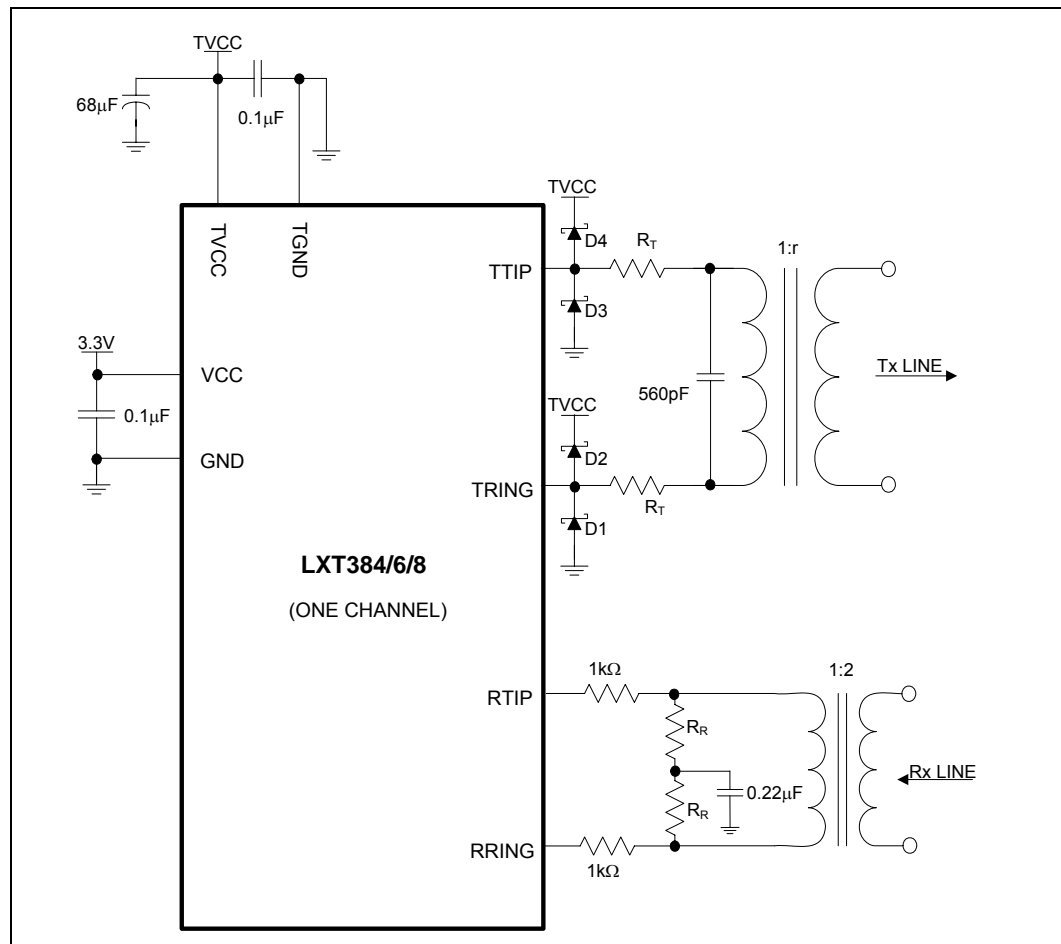

2.0 LXT384/6/8 T1/E1 LIU Family

The family of Cortina Systems® 3.3 V T1/E1 LIUs include the following members:

- LXT384 LIU: Eight channel T1/E1 LIU with clock recovery and digital jitter attenuator (hardware/software mode).
- LXT386 LIU: Four channel version of the LXT384.
- LXT388 LIU: Dual LIU with four receivers. Feature set is identical to the LXT384 LIU with the addition of simultaneous receive and transmit jitter attenuator and DPM (Driver Performance Monitoring).

These devices have identical receive and transmit circuits. The following discussion applies to all three devices unless otherwise noted.

3.0 Standard Line Interface Circuitry

Figure 1 shows the line interface circuitry as recommended in the LXT384/6/8 T1/E1 LIU datasheets.

In the transmit section, the R_T resistors change from E1 to T1. In T1 mode, series resistors are only supported when the transmitter power supply (TVCC) is set to 5 V.

In the receive section, the R_R resistors are selected so that the input impedance offered by the receive circuitry matches the characteristic line impedance. Therefore, R_R is such that:

Equation 1 $Z_L = r^2 (2 R_R)$

Where Z_L is the line characteristic impedance and r is the transformer turns ratio (in this case $r = 2$). Consequently, to obtain optimum impedance matching and receive return loss performance, the designer typically changes R_R when the line impedance changes. This is the case going from a T1 100 Ω line impedance to an E1 120 Ω line impedance.

In the following section we will show that simple solutions exist for supporting T1/E1 twisted pair interfaces without component changes. Transmit and receive interfaces are addressed in separate sections. The performance tradeoffs for each of the suggested configurations is discussed. Test data is provided along with the recommended configurations.

Note that E1 coaxial cable interface is not addressed in this Application Note as most of the modern designs use twisted pair interfaces. In many applications, support for coaxial cable can be added with external baluns. For more information on supporting E1 coaxial and twisted pair interface in the same design, please refer to the LXT384 LIU FAQ and the "LXT380 Design Assistant". Contact your Sales office for these materials.

4.0 Universal T1/E1 Interface

4.1 Transmit Interface

Two different T1/E1 transmit interface options are proposed in this section: a *high transmit return loss* interface and a *low power* interface.

4.1.1 High Transmit Return Loss Interface

Transmit return loss is a measure (in dB) of the matching between the line impedance and the transmit interface impedance. High transmit return loss minimizes reflections and ensures quality transmission over harsh cable environments. The configuration illustrated in Figure 2 can be used for both T1 and E1 operation while maintaining excellent transmit return loss performance.

Figure 2 High Tx Return Loss Interface

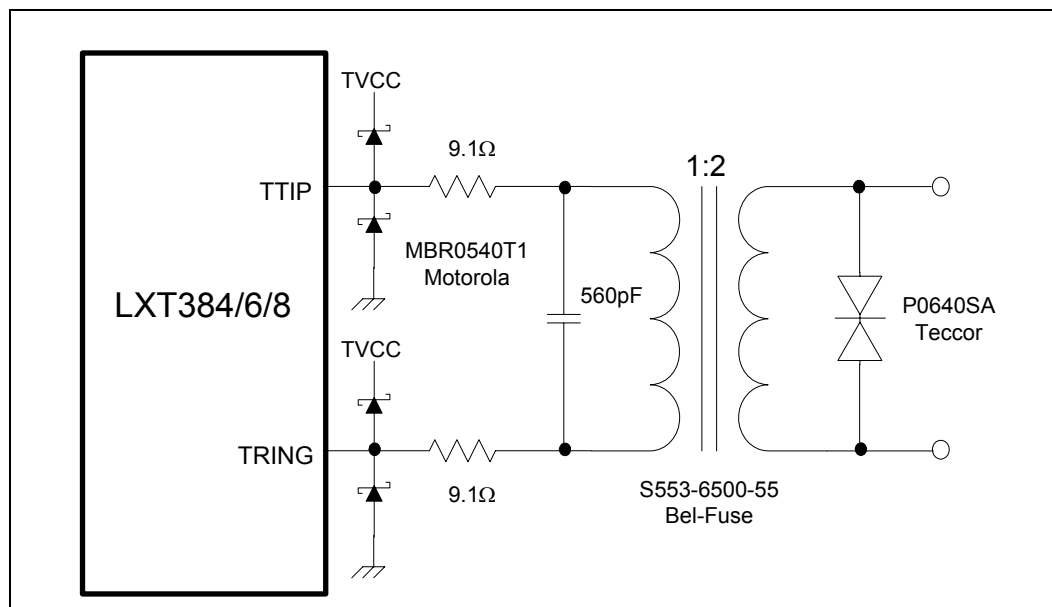

For T1 operation, this configuration coincides with the standard recommended interface. Its performance is therefore well characterized in the product datasheet. For E1, twisted pair operation, the transmit series resistors are slightly lower than the recommended value ($R_T = 11 \Omega$). The transient voltage suppressor and Schottky diodes were added for surge protection. Although Cortina recommends this protection for increased reliability, they are not mandatory for normal operation.

4.1.1.1 Pulse Template Measurement

The output voltage in E1 mode using this configuration is slightly higher than nominal. Cortina measured a typical value of 3.2 V which is within the ITU-T G.703 specified range: $2.7 \text{ V} < V_0 < 3.3 \text{ V}$. Figure 3 shows the resulting output pulse as measured using the LXT384 LIU evaluation board. Note: in typical applications, long pcb traces, protection elements, EMI filters and connectors will add resistive loss that effectively reduces the output level at the measurement point. In these application, the increased output amplitude may actually result in additional margin to the pulse template specifications.

Figure 3 E1, Twisted Pair Cable Output

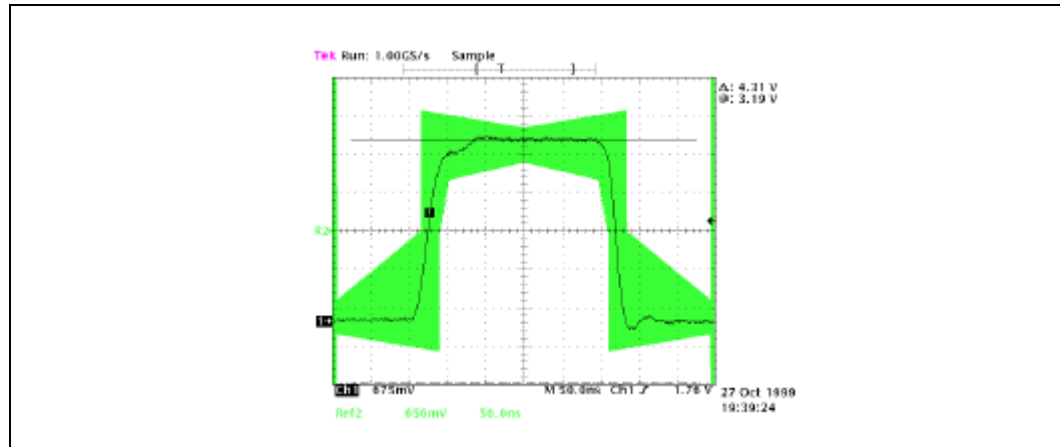

4.1.1.2 Transmit Return Loss Measurement

This configuration offers excellent transmit return loss performance exceeding the requirements in ETS300166 by a comfortable margin. Please refer to [Figure 4](#).

Figure 4 E1 Twisted Pair, Tx Return Loss

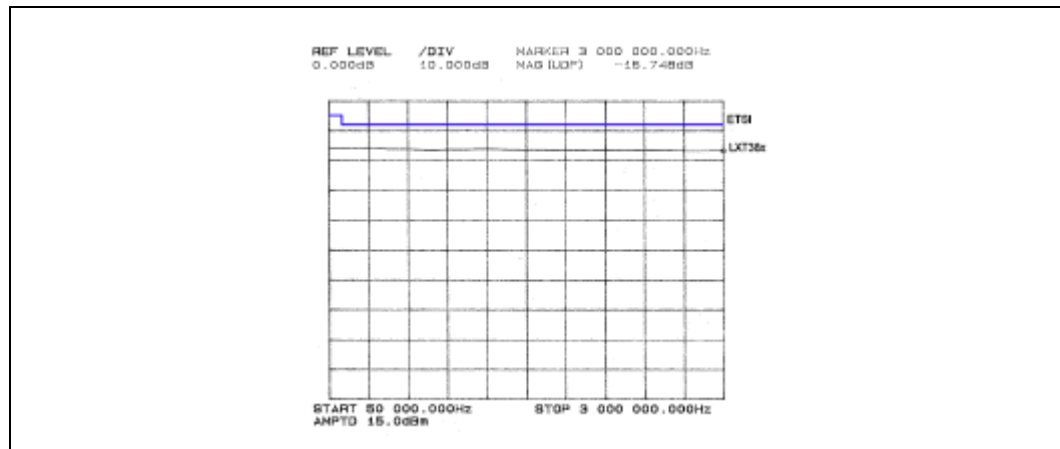

4.1.1.3 Low Power Interface

[Figure 5](#) represent a low power solution for T1/E1 twisted pair cable interface. By using a transformer with a lower turns ratio, we effectively reduce the current consumption through the TVCC pins (TVCC = 5 V).

Figure 5 Low Power Interface

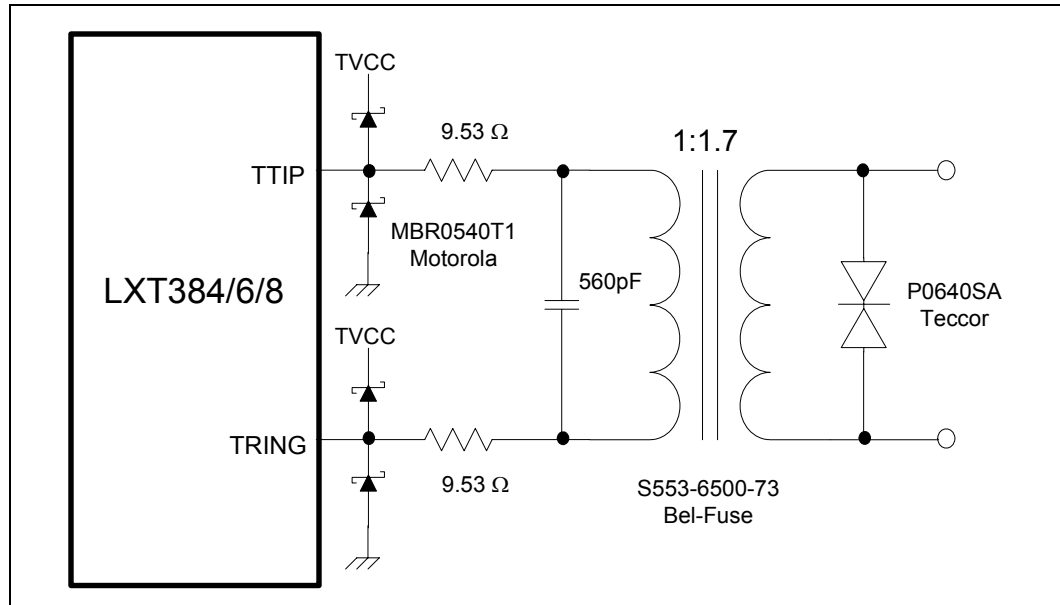

4.1.1.4 Pulse Template Measurement

Since this configuration is not standard in the LXT38x datasheets, both T1 and E1 pulse template measurements were performed. Figure 6 through Figure 16 illustrate the measurements.

Figure 6 E1, Twisted Pair Cable Output

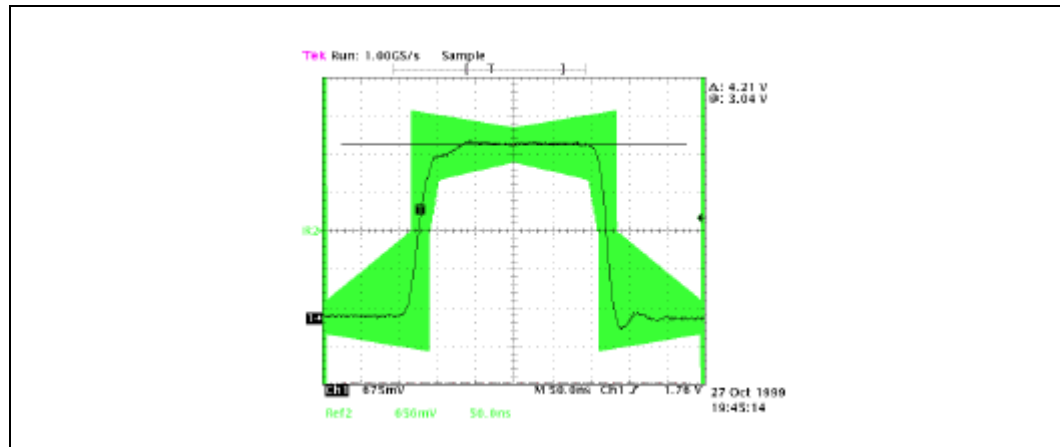

Figure 10 T1, LEN = 100 @ 262 ft. Cable

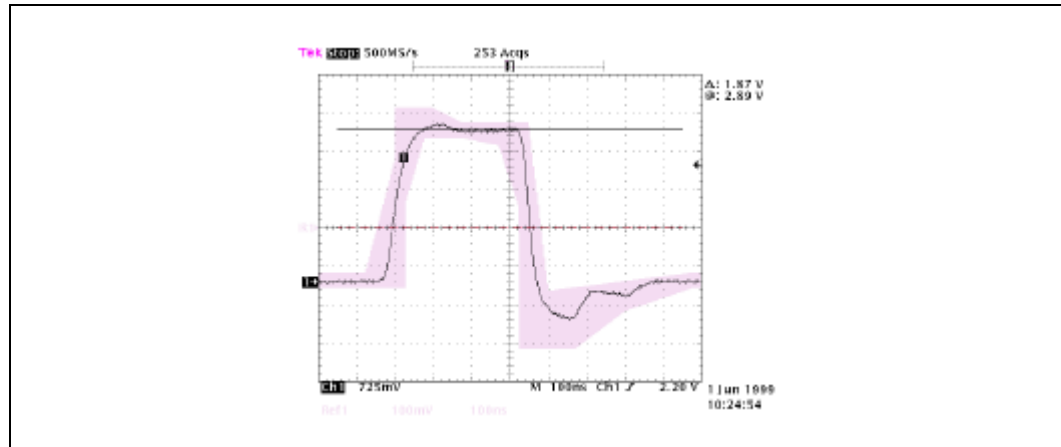

Figure 11 T1, LEN = 101 @ 262 ft. Cable

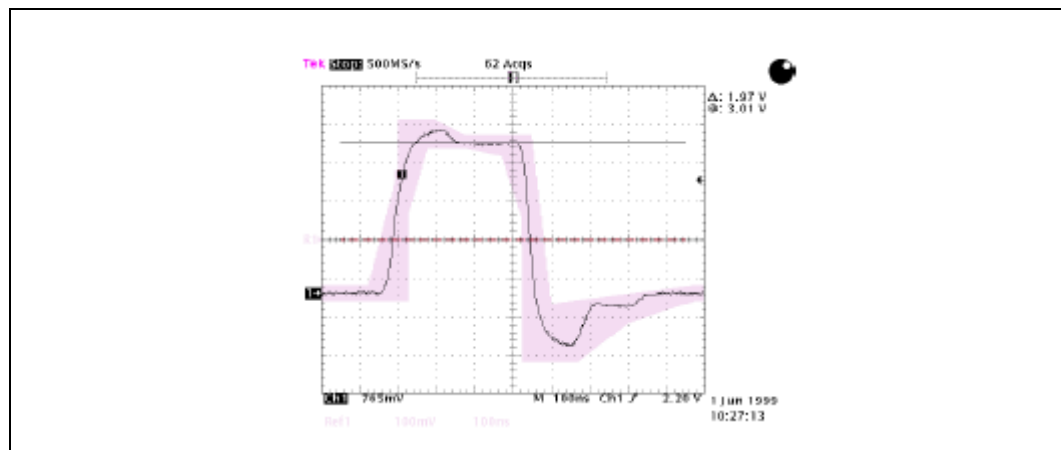

Figure 12 T1, LEN = 101 @ 393 ft. Cable

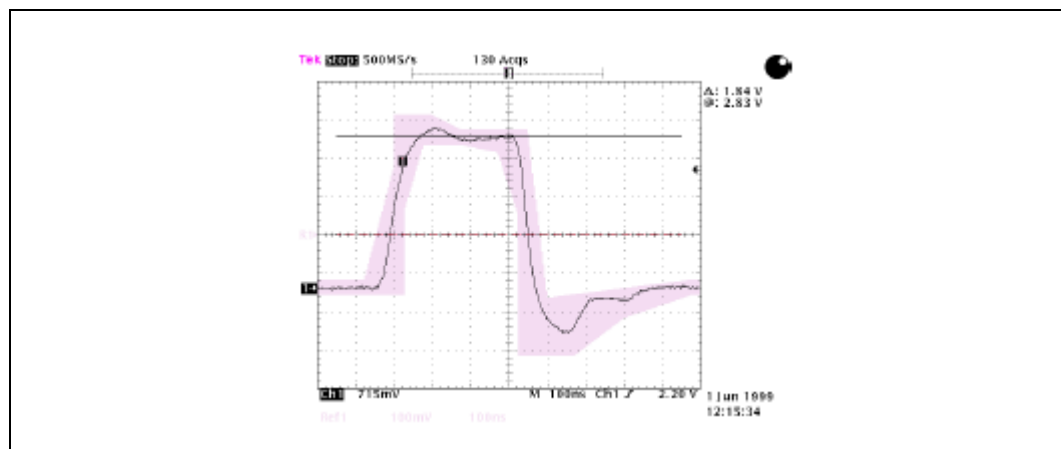

Figure 13 T1, LEN = 110 @ 393 ft. Cable

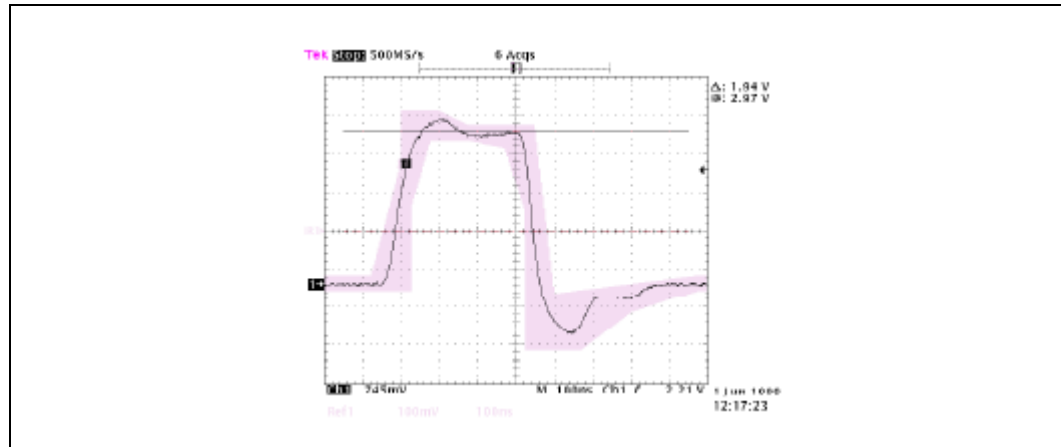

Figure 14 T1, LEN = 110 @ 524 ft. Cable

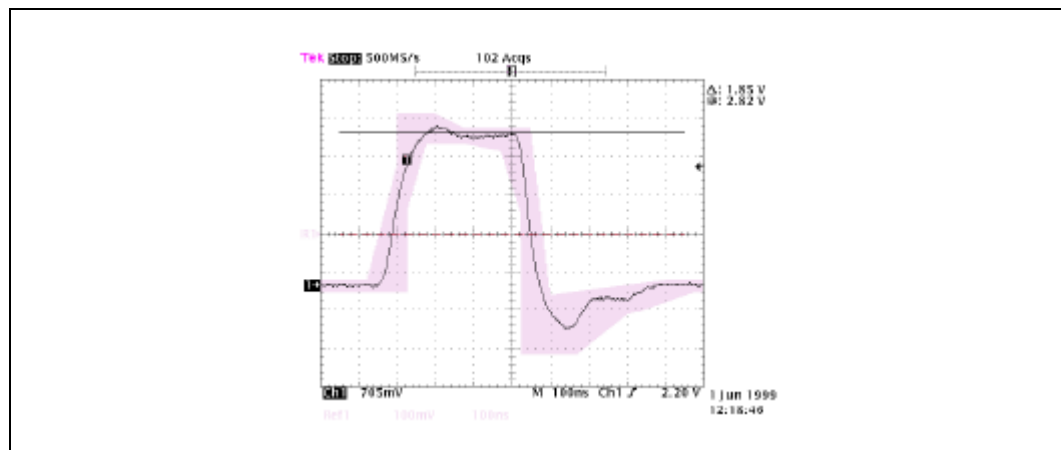

Figure 15 T1, LEN = 111 @ 524 ft. Cable

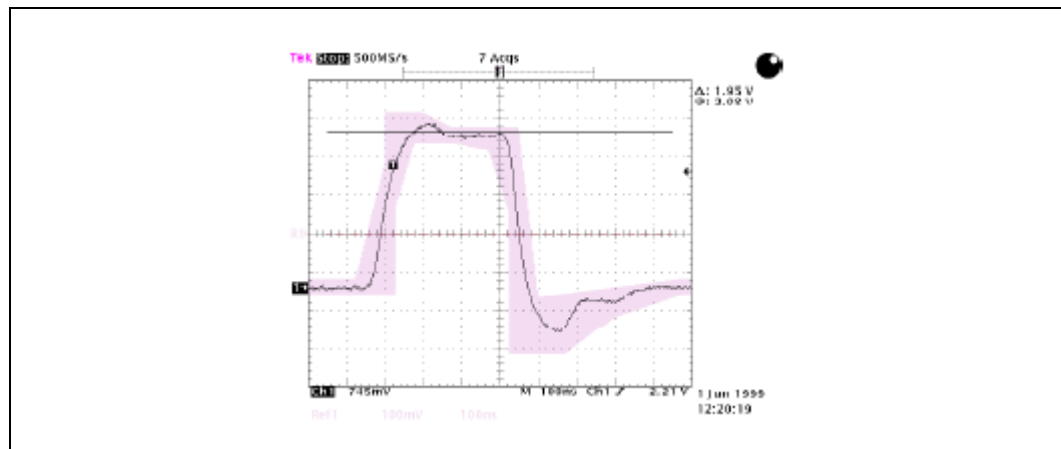
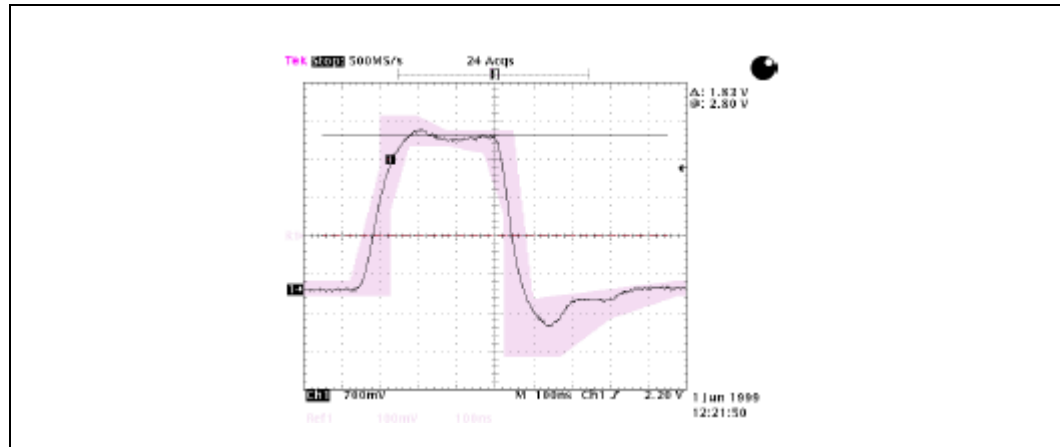

Figure 16 T1, LEN = 111 @ 655 ft. Cable



4.1.1.5 Transmit Return Loss Measurement

Although transmit return loss performance in this configuration is not as good as the performance offered by the configuration described in the previous section, it is still enough to meet the requirements of ETS 300166. Note that there are no return loss specification for T1. In this application note, the corresponding E1 limits are used as a reference for the T1 measurements. Figure 17 and Figure 18 show the transmit return loss measurements.

Figure 17 T1 Twisted Pair, Tx Return Loss

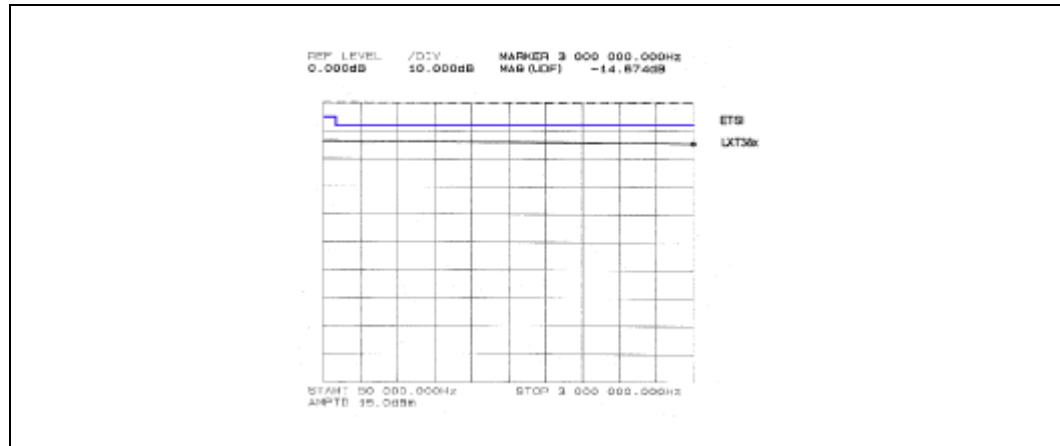
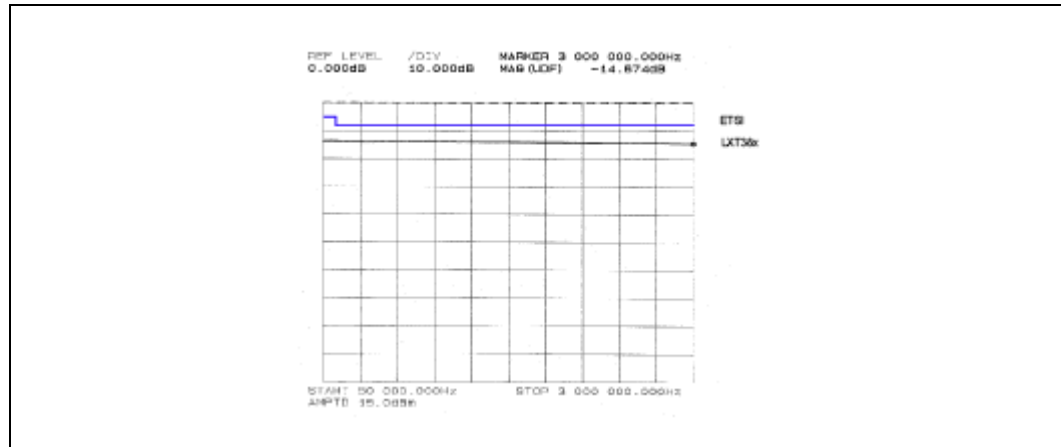

Figure 18 E1 Twisted Pair, Tx Return Loss



4.2 Transmit Interface Summary

As we saw in the previous sections, the two proposed transmit interfaces offer different tradeoffs between transmit return loss, pulse template and power consumption performance. Therefore, the right interface for a given application is going to depend on which of these parameters is the most critical for the design. [Table 1](#) summarizes the performance characteristics of both interfaces.

4.2.1 Receive Interface

As we saw in the standard receive interface description, the receive termination resistors R_R are usually modified to match different line impedances. While this practice yields optimum receive return loss performance, it is not necessary to exactly match the line impedance in order to meet the receive return loss requirements with a comfortable margin. The receive interface we are about to propose takes advantage of this fact. Since the T1 and E1 twisted pair characteristic impedances (100 Ω and 120 Ω) are relatively close, we can use a compromise 110 Ω equivalent impedance to terminate both interfaces. Please refer to [Figure 19](#).

Figure 19 T1/E1 Receive Interface

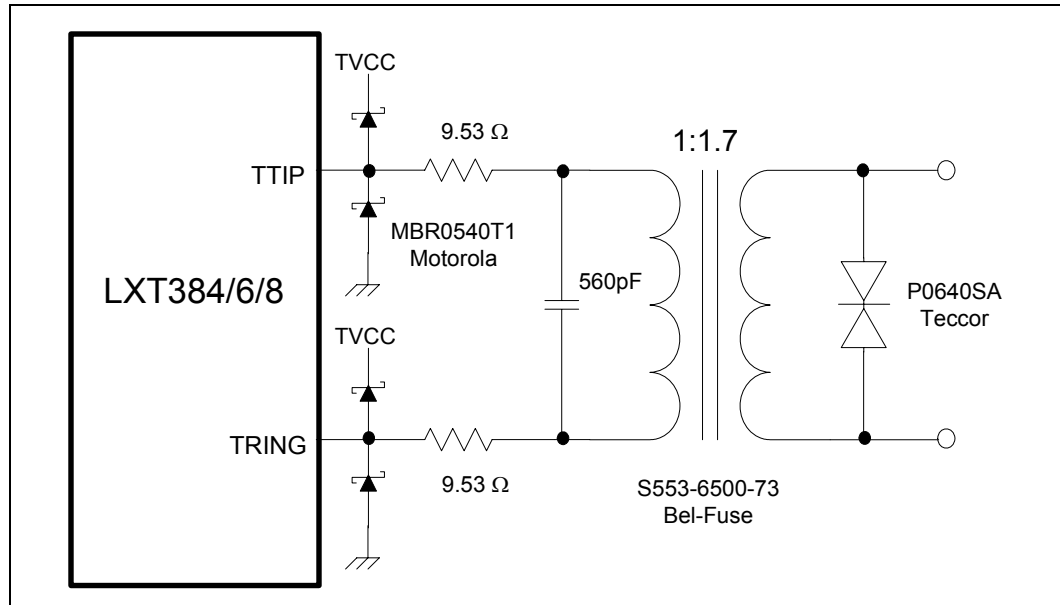

The reflected impedance Z is:

Equation 2 $Z = r^2 (2 R_R) = 2^2 \times (2 \times 13.7) = 109.6 \Omega$

With this termination impedance, we can easily meet G.703 receive return loss requirements as shown in Figure 20. On the other hand, the T1 receive return loss is still well above 20 dB in the same frequency range. Note that these measurements also take into account the capacitive loading effect of the protection sidactor.

Figure 20 E1 Twisted Pair, Tx Return Loss

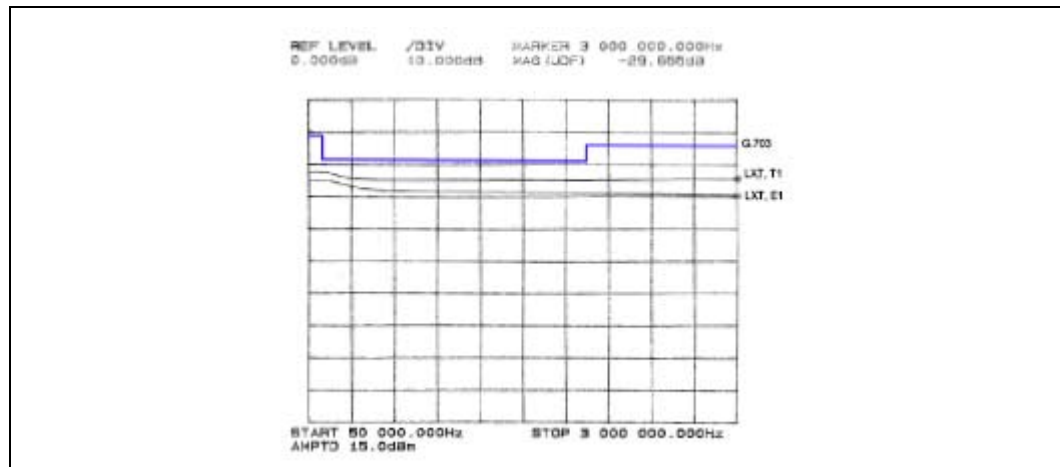

Table 1 Transmit Interface Performance Summary

	Per Channel $I_{TVCCmax.}^{1,2}$		Tx Return Loss typ.	
	T1	E1	T1 f = 772 KHz	E1 f = 1024 KHz
High Return Loss Option Figure 2	62 mA	34 mA	21 dB	16 dB
Low Power Option Figure 5	51 mA	27 mA	14 dB	11 dB

1. Add total I_{VCC} for total power consumption calculations.
 2. $TVCC = 5 V \pm 5\%$

5.0 Conclusions

In the previous sections, we proposed simple solutions for T1/E1 twisted pair operation without component changes using the LXT38X series of 3.3 V T1/E1 LIUs. These devices offer the flexibility to support different tradeoffs between power consumption and transmission performance. As a result, the designer can choose the interface circuit that better suits his requirements while meeting the applicable standards with a comfortable margin.



For additional product and ordering information:

www.cortina-systems.com