



IP Telephony and DTE Discovery Using Cortina Systems[®] Ethernet PHYs

Application Note

30 March 2007

Document Number 249611

Revision 2.0

*Other names and brands may be claimed as the property of others.

© Cortina Systems, Inc. 2007

Contents

1.0	Introduction.....	3
1.1	Data and Voice Networks Convergence.....	3
1.2	Definitions.....	4
2.0	IP Telephony Systems and Components	5
2.1	Improving IP Telephony Quality and Cost with Cortina Systems, Inc. Networking Silicon ...	5
2.2	IP Telephone	6
2.2.1	IP Telephone Components.....	6
2.2.2	LXT973 Transceiver is an Ideal PHY Solution for IP Telephones	6
2.2.3	IP Telephone Power and Discovery Filter.....	6
2.3	VoIP-Enabled Switch	8
2.3.1	VoIP-Enabled Switch System Components.....	8
2.3.2	LXT9785E Transceiver Provides VoIP-Enabled Switch System DTE Discovery ...	9
3.0	DTE Discovery and Power Application by the Switch System	10
3.1	Step-by-Step DTE Discovery Process	10
3.2	Management Interface and Control Registers	10
3.3	DTE Discovery Process Flow	11
3.4	Software Flow Examples for DTE Discovery with Various Link Partners	13
4.0	Summary	20
4.1	References	20

Figures

1	Typical IP Telephony System with Data Connections and Power Source for Each Component ...	5
2	IP Telephone Block Diagram.....	6
3	Network Connection Between a VoIP-Enabled Switch and an IP Phone.....	7
4	Typical IP phone filter implementation.....	7
5	VoIP-Enabled Switch Block Diagram for a 24-Port Solution	9
6	Flow Chart of the LXT9785E Transceiver Negotiation Process Including DTE Discovery	12

Tables

1	Terms and Acronyms	4
---	--------------------------	---

Revision History

Revision 2.0 Revision Date: 30 March 2007
First release of this document from Cortina Systems, Inc.

Revision 001 Revision Date: 01 November 2001
Initial release.

1.0 Introduction

Today, the dynamic, intersecting environments of local and wide area networks (LANs and WANs) face the dual challenge of supporting increased data traffic and a growing demand for “application-aware” networking such as video services, Internet Protocol (IP) Telephony, and Quality of Service (QoS). Metropolitan area networks (MANs) also have emerged, with a promise of high-speed optical access and high-reliability Internet Protocol (IP) data transmission. Ethernet has proven ideal for these “next generation” networks, as telecommunications and networking equipment providers require building blocks for cost-effective, reliable communications solutions.

This application note introduces the benefits and challenges of implementing IP Telephony in Ethernet networks, and explains the system hardware and software required to implement IP Telephony. The document briefly describes the components needed to enable this technology as a complete system and focuses on how to implement the Data Terminal Equipment (DTE) Discovery feature found in the Cortina Systems® LXT9785E enhanced 10/100 Octal Transceiver (LXT9785E Transceiver). The DTE Discovery process allows an IP phone to be powered over the data cable rather than over an external power outlet, which is similar to the way traditional telephones operate. This provides a method for network OEMs to offer “lifeline” services in their systems with products and technology available today.

1.1 Data and Voice Networks Convergence

The vision of a single corporate network to handle all communications is becoming a reality as Ethernet delivers on the promise of low-cost support of data and voice traffic over IP (VoIP). Enterprise and small business customers who consider the adoption of IP Telephony are finding that they can truly benefit from the reduced complexity (installation, maintenance, etc.) of a single network. IP Telephony can also reduce capital expenses, and may reduce the overall cost of telecommunications services by allowing calls between branch offices to take place over the Internet or a dedicated WAN infrastructure.

1.2 Definitions

Table 1 defines terms and acronyms used throughout this document.

Table 1 Terms and Acroynms

Term	Definition
DTE	Data Terminal Equipment (typically a IP telephone)
FLP	Fast Link Pulse
IP	Internet Protocol
LAN	Local Area Network
Link Partner	A device connected to the LXT9785E Transceiver through a twisted-pair cable
MAC	Media Access Controller (an Ethernet framer typically integrated into the switch ASIC)
MLT3	Multi-Level Transmitter-3
Negotiation Process	The process to establish link and a common operating mode, which includes the auto-negotiation and parallel detection processes
NLP	Normal Link Pulse
PHY	Physical layer transceiver (LXT9785E Transceiver, unless otherwise noted)
QoS	Quality of Service
System	The switch system using the LXT9785E Transceiver for DTE Discovery
VOIP	Voice over IP
WAN	wide area network

2.0 IP Telephony Systems and Components

2.1 Improving IP Telephony Quality and Cost with Cortina Systems, Inc. Networking Silicon

As with any new technology, barriers to adoption exist for IP Telephony, but Cortina Systems, Inc. and its OEM partners are developing IP Telephony solutions to remove these barriers. One barrier to adoption is the perception that IP telephone systems are not as tolerant to power failures as traditional phone systems. When a power failure occurs, a traditional telephone remains active, providing “lifeline” services, because it is receiving power over the cable from the PBX, which is running on an uninterrupted power source (UPS) or a back-up generator. However, an IP telephone, which is connected to a VoIP-enabled switch and receives power from an office power outlet, may not function during a power failure. System designers that use the LXT9785E Transceiver with DTE discovery functionality can provide power directly over the data cable connected to the IP telephone. If the switch system is connected to a backup power source, it can provide “power fault-tolerance,” and, therefore, lifeline services. Overall network cost may be reduced by eliminating the need for an AC power supply in each IP telephone.

On the desktop, Cortina offers the Cortina Systems® LXT973 Dual-Port Transceiver for IP telephones, which typically require two 10/100 ports — one to connect to the switch and the other to connect to the desktop PC (see Figure 1). By combining two low-power transceivers into a single product, Cortina reduces the overall cost and complexity of the telephone design.

Figure 1 Typical IP Telephony System with Data Connections and Power Source for Each Component

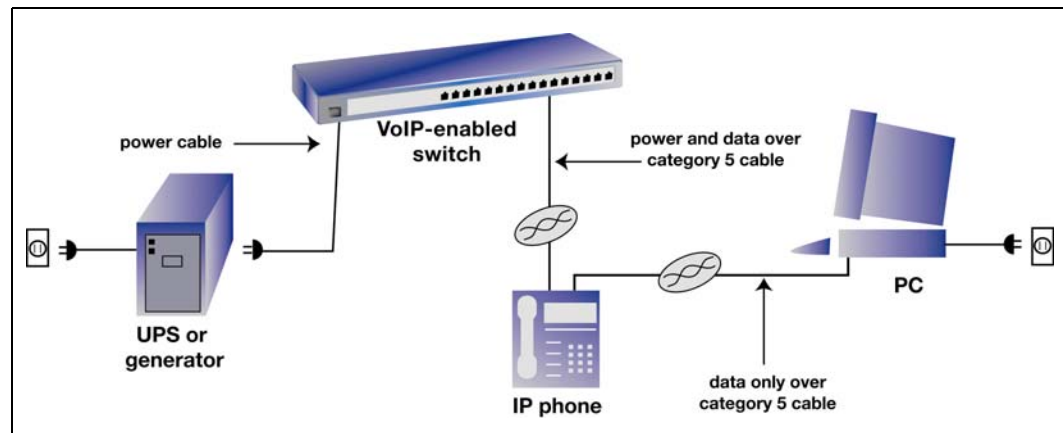

2.2 IP Telephone

2.2.1 IP Telephone Components

An IP telephone typically consists of an IP phone processor, interface logic, voice codec, and a dual-port PHY, as depicted in [Figure 2 on page 6](#). The processor provides the logic to make phone calls as well as a digital signal processor to manipulate voice packets. A dual-port PHY is typically used in a phone to provide an in-line connection between the LAN jack in an office wall and a desktop PC. This eliminates the need to cable a second LAN jack. To provide remote power capabilities, the IP telephone must also have a filter across the twisted-pairs in the LAN connection port.

Figure 2 IP Telephone Block Diagram

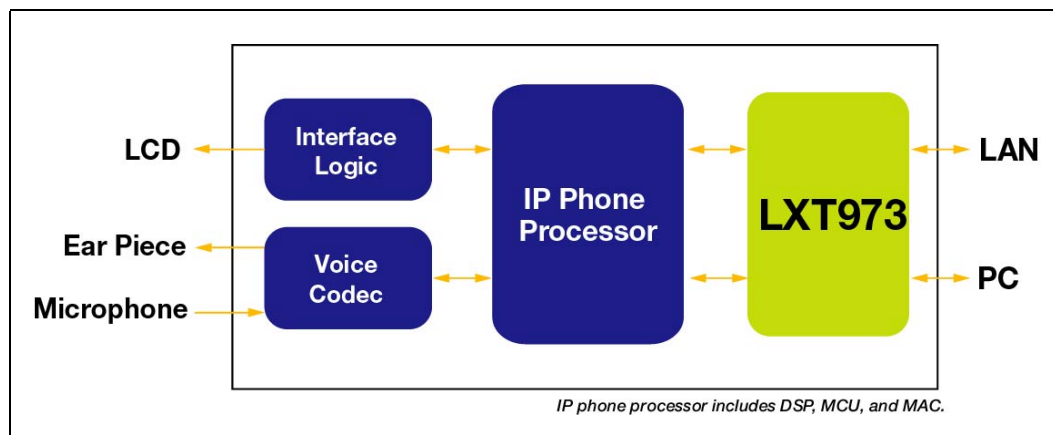

2.2.2 LXT973 Transceiver is an Ideal PHY Solution for IP Telephones

The LXT973 Transceiver is a low-power transceiver ideal for IP telephone applications requiring two Ethernet connections. In addition to superior PHY features such as low-power, extended cable distance, and auto MDI/MDIX, LXT973 Transceiver can reduce overall complexity of IP telephone designs. See [Figure 2](#) for a typical IP telephone block diagram.

2.2.3 IP Telephone Power and Discovery Filter

The DTE discovery process creates requirements on the VoIP-enabled switch and IP phone. The switch needs a 48-volt power supply that can source 300 mA for each port. This power supply also needs to have current limiting and protection circuitry. The IP phone is required to implement a filter path between the receive and transmit pairs only when the phone is not powered. The filter must be by-passed when power is applied to the IP phone. The phone must also convert the power down from 48 volts, as required for the internal circuitry.

[Figure 3](#) shows both ends of a network connection over which the DTE discovery process and remote powering of the phone take place.

Figure 3 Network Connection Between a VoIP-Enabled Switch and an IP Phone

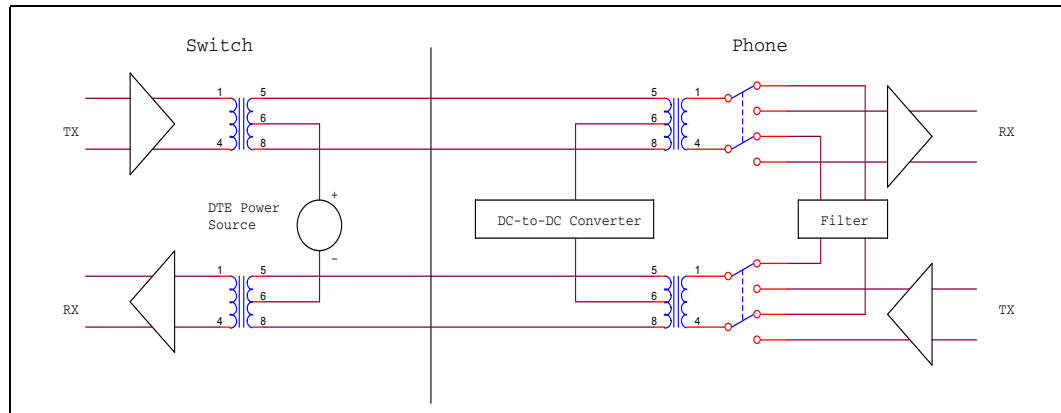

The phone's filter path has the following requirements:

- The filter should be able to pass Normal Link Pulses (NLPs) and Fast Link Pulses (FLPs), but block 100 Mbps Multi-Level Transmitter-3 (MLT3) signals and 10 Mbps Manchester-encoded signals.
- The 100 Mbps MLT3 and 10 Mbps Manchester-encoded signals need to be blocked to ensure that when the phone is connected to a forced-speed link partner, rather than a VoIP-enabled switch port, the link partner cannot establish link with itself.
- This filter should be non-polarized to ensure that auto MDI/MDIX does not affect operation.

The required filtering may be accomplished with a three-pole filter similar to the one shown in [Figure 4](#).

Figure 4 Typical IP phone filter implementation

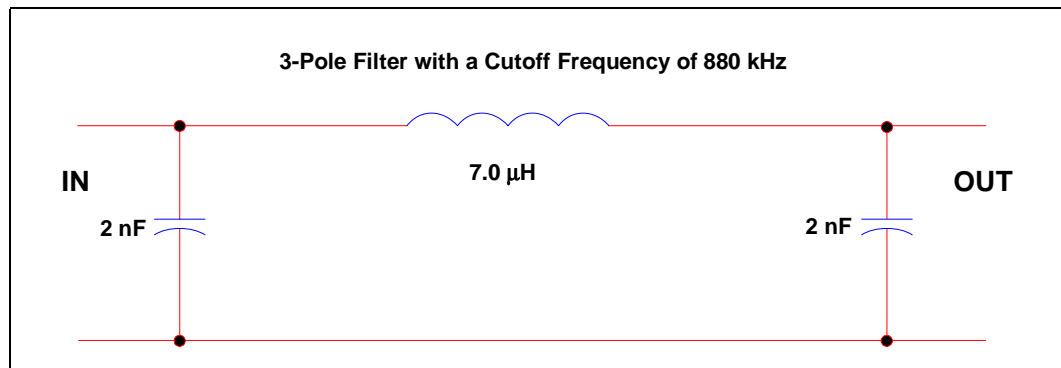

2.3 VoIP-Enabled Switch

2.3.1 VoIP-Enabled Switch System Components

A VoIP-enabled switch consists of many of the same components as a typical Ethernet switch, but with additional IP Telephony software and circuitry to control DTE Discovery and power application. The components typically found in a VoIP-enabled switch include:

- A switch engine to switch data using QoS functions
- Transceivers to receive and transmit data
- A processor to manage the system
- A power supply unit to provide power to the switch and the data cables

[Figure 5 on page 9](#) shows a high-level block diagram depicting the interfaces between the typical components found in a VoIP-enabled switch with DTE Discovery and remote powering capabilities.

The state machine that controls the DTE Discovery process resides within the LXT9785E Transceiver. The processor controls the power supply and the overall system. The processor communicates with the Power Supply Unit (PSU) and applies power to the twisted-pair cable, depending on the data supplied by the PHY. The PHY register data is transmitted on the MDIO interface via the MAC function in the switch. The required control bits are contained in the PHY register map and are discussed in detail in [Section 3.2, Management Interface and Control Registers, on page 10](#).

Figure 5 VoIP-Enabled Switch Block Diagram for a 24-Port Solution

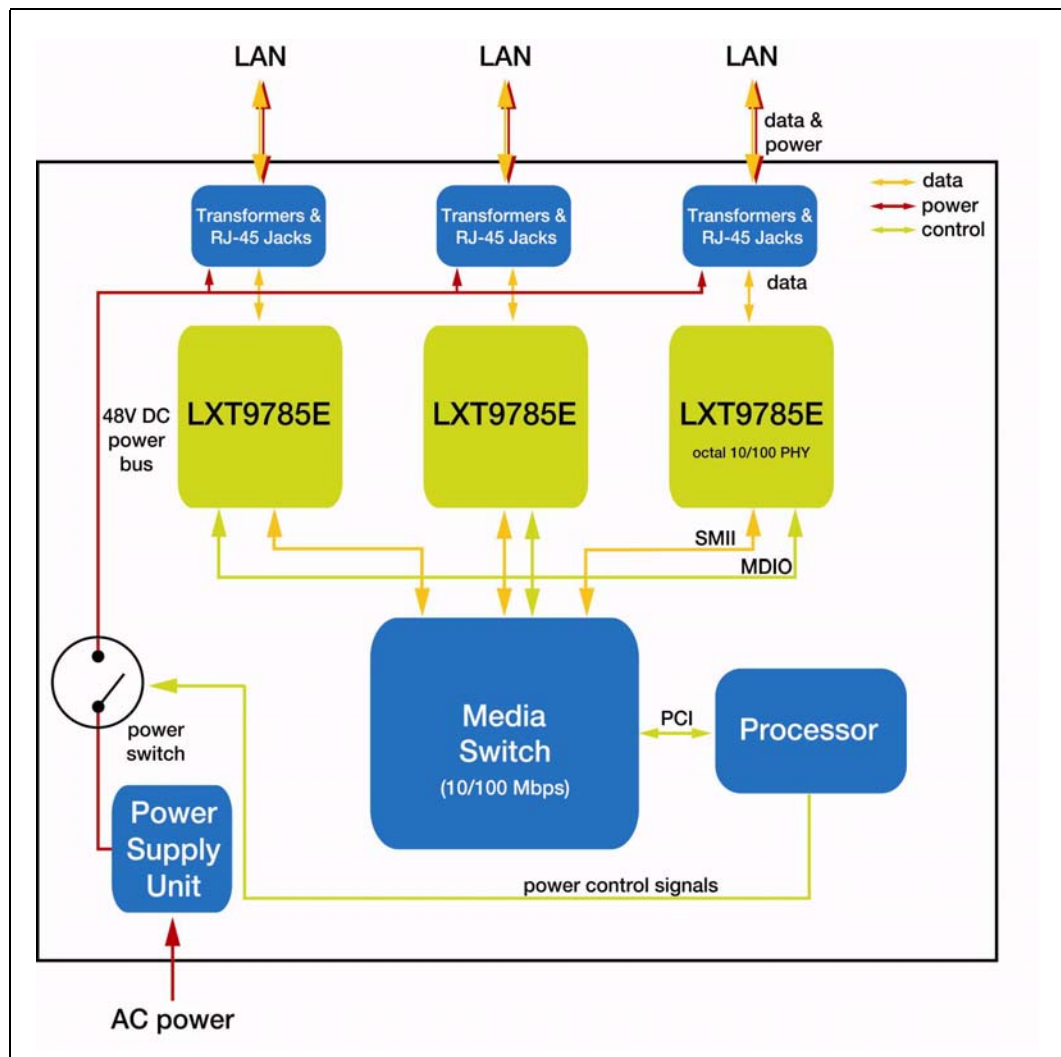

2.3.2 LXT9785E Transceiver Provides VoIP-Enabled Switch System DTE Discovery

The LXT9785E Transceiver is a low-power transceiver optimized for use in VoIP-enabled switch systems. Each port of the LXT9785E Transceiver can discover whether an IP telephone is on the other end of the network connection and can inform the switch processor of this information.

The DTE Discovery process is independently controlled on each port and must be enabled through software. The process is implemented as a next page option to the auto-negotiation flow. The process depends upon the IP phone having a unique filter that passes NLPs and FLPs.

3.0 DTE Discovery and Power Application by the Switch System

The implementation of the processor/MAC interface and the processor/PSU interface are design specific, thus out of the scope of this document. An overview of the system control required to provide DTE Discovery and remote-power application is described below.

3.1 Step-by-Step DTE Discovery Process

1. The processor enables the discovery process on a given PHY port via the MDIO interface by setting the DTE Discovery Process Enable bit (27.6 = 1) and the Auto-Negotiation Enable bit (0.12 = 1).
2. The LXT9785E Transceiver then tests to see if a DTE requiring power is present as the link partner. If a DTE is found, the DTE Discovered bit (27.4) is set. The processor polls this signal via the MAC.
3. Upon detecting the DTE, the processor instructs external logic to apply power to the twisted- pair cable.
4. Once power has been applied to the DTE, normal negotiation takes place. The processor must enable the required negotiation process by restarting auto-negotiation, or by setting a forced speed mode after power has been applied. The processor must poll the Link-up Register bit (1.2) in the corresponding LXT9785E Transceiver port, or the link status change interrupt, to ensure that link has been established.
5. A time-out feature must be included so that if link is not established within a pre-determined time period (system dependent), the processor instructs the power supply to switch off. If link is not established prior to the expiration of the Link Fail Inhibit Timer, the LXT9785E Transceiver restarts negotiation.
6. If power is applied and link is established, the processor must still poll the Link-up Register bit (1.2) or the link status change interrupt in the corresponding LXT9785E Transceiver port. This indicates when a link partner has been removed from the network. On seeing the link-down condition, the processor instructs the power supply to switch off, and the DTE Discovery and negotiation processes begin again unless they are disabled.

3.2 Management Interface and Control Registers

Management and control of the DTE discovery process is via the MDIO port. Each port on the LXT9785E Transceiver is independently controlled and capable of running the discovery process. The implementation of the DTE Discovery process is through a dedicated set of control and status bits found in Register 27. The operation of each of these register bits is described below:

- DTE Discovery Process Enable – Register Bit 27.6 (Dis_En)
 - Read/Write Register
 - Default value = 0: Disabled

Bit 27.6 controls the operation of the process. The discovery process is disabled when bit 27.6 = 0, and enabled when bit 27.6 = 1. The MAC controller sets bit 27.6 to 1 when a port search for a DTE requiring power is desired. Bit 27.6 remains set until the MAC clears it, either by directly clearing it or by resetting the PHY. This allows the discovery process to continue to function if unsuccessful in detecting a DTE, without

being continually re-enabled by the MAC. If bit 27.6 is set after link is established, no action is taken until after the link goes down.

- DTE Discovered – Register Bit 27.4 (DTE_Dis)

- Read Only Register

- Default value = 0: No DTE found

Bit 27.4 contains the result of the discovery process. When bit 27.4 = 0, the discovery process has not found an IP phone, and when bit 27.4 = 1, the discovery process has successfully found a DTE requiring power. Bit 27.4 is polled by the MAC during the discovery process, and is cleared when the PHY is reset, when auto-negotiation is restarted, or when auto-negotiation is disabled. If the discovery process is interrupted due to detection of an already powered link partner (auto-negotiation completion or Parallel Detection), bit 27.4 = 0.

- Non-Phone Detected – Register Bit 27.3 (NP_Det)

- Read/Write Register, Clear on Read

- Default value = 0: No non-phone found

When bit 27.3 = 1, a non-phone link partner has been detected by the LXT9785E Transceiver (NLPs, MLT3 data, FLPs without next page support, or FLPs with non-matching next pages). When bit 27.3 = 0, other bits are checked to determine overall status of the link partner. Bit 27.3 is cleared on Read, DTE discovery is disabled, link is established, auto-negotiation is restarted, or auto-negotiation is disabled.

- Link Fail Time Out – Register Bit 27.2 (LFIT_IND)

- Read/Write Register, Clear on Read

- Default value = 0: Link Fail Inhibit Timer has expired without establishment of link

When bit 27.2 = 1, the Link Fail Inhibit Timer has occurred since a non-phone link partner was detected. Bit 27.2 is cleared on Read, DTE discovery is disabled, link is established, auto-negotiation is restarted, or auto-negotiation is disabled.

3.3 DTE Discovery Process Flow

When DTE Discovery (27.6 = 1) and auto-negotiation (0.12 = 1) are enabled, the LXT9785E Transceiver transmits the auto-negotiation base page with the Next Page Ability bit set (Auto-Negotiation Advertisement Register [Address 4]).

System software polls Register 27 to determine if and when a phone is detected. The receiver monitors the line to determine if NLPs, MLT3 data, or FLP bursts are being received. If the receive activity is FLP bursts, the status of the Next Page Ability bit is checked. If the detected link partner also supports Next Page, then the LXT9785E Transceiver transmits the next page sequence associated with message code #5 (Organizationally Unique Identifier [OUI] Tag Code). The Next Pages to be sent for this message code include user-defined code values loaded with random data created by the LXT9785E Transceiver. The Next Pages are hard-coded in the logic and the LXT9785E Transceiver ignores any data written into Register 7. The receiver monitors the next pages to determine that the exact Next Page data, including the random data transmitted, is received. The DTE_Dis bit (27.4) is set when a potential IP Phone is detected as the link partner, and the last Next Page is repeatedly transmitted until software restarts the negotiation process. [Figure 6](#) indicates the DTE Discovery steps added to the standard IEEE 802.3 negotiation process.

The negotiation process establishes link if a compatible mode exists between the LXT9785E Transceiver and the link partner. If a compatible mode does not exist (not compatible or not established within the Link Fail Inhibit Timer period), one of the following actions occurs:

- If DTE discovery and auto-negotiation are enabled, LXT9785E Transceiver restarts auto-negotiation and DTE discovery.
- If DTE discovery is disabled and auto-negotiation is enabled, LXT9785E Transceiver restarts normal negotiation.
- If DTE discovery and auto-negotiation are disabled, LXT9785E Transceiver continues to transmit either 10M NLPs or 100M IDLE symbols.

Regardless of the action that takes place, the software must detect this non-link state and disable the power to the cable.

3.4 Software Flow Examples for DTE Discovery with Various Link Partners

The following sections describe a typical software flow that must be written for various types of link partners. This software is written by the OEM and is run on the processor, utilizing the registers in the LXT9785E Transceiver for DTE discovery control and status information.

Each of these examples assumes that the LXT9785E Transceiver has been initialized to perform DTE discovery and auto-negotiation. When DTE discovery (27.6) and auto-negotiation (0.12) are enabled, the DTE discovery-related register bits should be:

DTE Discovery Enabled (Dis_En)	27.6 = 1
DTE Discovered (DTE_Dis)	27.4 = 0
Non-Phone Detected (NP_Det)	27.3 = 0
Link Fail Time Out (LFIT_IND)	27.2 = 0

Note that the software flow is exactly the same from the software developer's perspective for Examples 2 through 6. The LXT9785E Transceiver does all of the work to distinguish between these scenarios. However, Examples 1 and 7 require unique software intervention, which is discussed in their respective sections.

Example 1 Link Partner — IP Phone

System software polls Register 27 to determine if or when a phone is detected. Once the link partner has been connected to the switch, the negotiation process begins. The receiver monitors the next pages to determine that the exact next page data transmitted is received. They match in this case and the LXT9785E Transceiver sets the DTE_Dis bit (27.4) because a potential IP phone is detected as the link partner:

DTE Discovery Enabled (Dis_En)	27.6 = 1
DTE Discovered (DTE_Dis)	27.4 = 1
Non-Phone Detected (NP_Det)	27.3 = 0
Link Fail Time Out (LFIT_IND)	27.2 = 0

The software should be written so that the negotiation is not restarted until the phone is powered up. The DTE_Dis bit (27.4) is cleared upon restarting or disabling auto-negotiation (selecting forced mode). The system must be capable of detecting over-

current conditions and disabling power in case a cross-over cable is used to connect the system with the phone. Once the IP phone's power is stabilized and sufficient time has passed for the phone to initialize, the auto-negotiation process may be restarted.

DTE Discovery Enabled (Dis_En)	27.6 = 1
DTE Discovered (DTE_Dis)	27.4 = 0
Non-Phone Detected (NP_Det)	27.3 = 0
Link Fail Time Out (LFIT_IND)	27.2 = 0

The negotiation process establishes link because a compatible mode exists between the switch using the LXT9785E Transceiver and the IP phone.

Example 2 Link Partner — Normal PHY in Auto-Negotiation Mode with Next Page

The system software polls Register 27 to determine if or when a phone is detected. Once the link partner is connected to the switch, the negotiation process begins. The receiver monitors the next pages to determine that the exact next page data transmitted is received. The next pages do not match in this case, and the LXT9785E Transceiver sets the Non-Phone Detected bit to indicate that a non-phone has been detected.

DTE Discovery Enabled (Dis_En)	27.6 = 1
DTE Discovered (DTE_Dis)	27.4 = 0
Non-Phone Detected (NP_Det)	27.3 = 1
Link Fail Time Out (LFIT_IND)	27.2 = 0

The software, upon detecting that the Non-Phone Detected bit is set (the bit is cleared on Read), can change the negotiation status of the LXT9785E Transceiver or allow the LXT9785E Transceiver to continue in auto-negotiation mode. The LXT9785E Transceiver continues auto-negotiation with the advertised modes until either the software has changed the negotiation status or link is established.

DTE Discovery Enabled (Dis_En)	27.6 = 1
DTE Discovered (DTE_Dis)	27.4 = 0
Non-Phone Detected (NP_Det)	27.3 = 0
Link Fail Time Out (LFIT_IND)	27.2 = 0

The negotiation process establishes link if a compatible mode exists between the LXT9785E Transceiver and the link partner. If the LXT9785E Transceiver establishes link but the software has not read the Non-Phone Detected bit, the Non-Phone Detected bit is cleared anyway once link is established.

If the LXT9785E Transceiver does not establish link within the Link Fail Inhibit Timer period and the software does not read the Non-Phone Detected bit, the Link Fail Time Out bit is set to inform software that a potential link partner other than a phone has been detected, but link cannot be established for some reason. There is no guarantee as to the current state of the connection or nor the status of LXT9785E Transceiver under this condition. Register 27 must be read again to determine the current system status.

DTE Discovery Enabled (Dis_En)	27.6 = 1
DTE Discovered (DTE_Dis)	27.4 = 0
Non-Phone Detected (NP_Det)	27.3 = 1
Link Fail Time Out (LFIT_IND)	27.2 = 1

Example 3 Link Partner — Normal PHY in Auto-Negotiation Mode without Next Page

The system software polls Register 27 to determine if or when a phone is detected. Once the link partner has been connected to the switch, the negotiation process begins. The detected “link partner” does not support next page, so the LXT9785E Transceiver transmits the base page and monitors the received base pages for compatibility to establish link. The Non-Phone Detected bit is set to indicate that a non-phone has been detected.

DTE Discovery Enabled (Dis_En)	27.6 = 1
DTE Discovered (DTE_Dis)	27.4 = 0
Non-Phone Detected (NP_Det)	27.3 = 1
Link Fail Time Out (LFIT_IND)	27.2 = 0

The software, upon detecting that the Non-Phone Detected bit is set (the bit is cleared on Read), can change the negotiation status of the LXT9785E Transceiver or allow the LXT9785E Transceiver to continue in auto-negotiation mode. The LXT9785E Transceiver continues auto-negotiation with the advertised modes until either the software has changed the negotiation status or link is established.

DTE Discovery Enabled (Dis_En)	27.6 = 1
DTE Discovered (DTE_Dis)	27.4 = 0
Non-Phone Detected (NP_Det)	27.3 = 0
Link Fail Time Out (LFIT_IND)	27.2 = 0

The negotiation process establishes link if a compatible mode exists between the LXT9785E Transceiver and the link partner. If the LXT9785E Transceiver establishes link but the software has not read the Non-Phone Detected bit, the bit is cleared anyway once link is established.

If the LXT9785E Transceiver does not establish link within the Link Fail Inhibit Timer period and the software does not read the Non-Phone Detected bit, the Link Fail Time Out bit is set to inform software that a potential link partner other than a phone has been detected, but link cannot be established for some reason. There is no guarantee as to the current state of the connection or LXT9785E Transceiver status under this condition. Register 27 must be read again to determine the current system status.

DTE Discovery Enabled (Dis_En)	27.6 = 1
DTE Discovered (DTE_Dis)	27.4 = 0
Non-Phone Detected (NP_Det)	27.3 = 1
Link Fail Time Out (LFIT_IND)	27.2 = 1

Example 4 Link Partner — Normal PHY in Forced Mode

The system software polls Register 27 to determine if or when a phone is detected. The receiver monitors the line to determine if NLPs, or MLT3 data, or FLP bursts are being received. The receive activity is NLPs or MLT3 data. The LXT9785E Transceiver transmits NLPs or MLT3 data respectively to try and establish link via parallel detection. The Non-Phone Detected bit is set to indicate that a non-phone has been detected.

DTE Discovery Enabled (Dis_En)	27.6 = 1
DTE Discovered (DTE_Dis)	27.4 = 0
Non-Phone Detected (NP_Det)	27.3 = 1
Link Fail Time Out (LFIT_IND)	27.2 = 0

The software, upon detecting that the Non-Phone Detected bit is set (the bit is cleared on Read), can change the negotiation status of the LXT9785E Transceiver or allow the LXT9785E Transceiver to continue in parallel detection. The LXT9785E Transceiver continues with parallel detection with the advertised modes until either the software has changed the negotiation status or link is established.

DTE Discovery Enabled (Dis_En)	27.6 = 1
DTE Discovered (DTE_Dis)	27.4 = 0
Non-Phone Detected (NP_Det)	27.3 = 0
Link Fail Time Out (LFIT_IND)	27.2 = 0

The negotiation process establishes link if a compatible mode exists between the LXT9785E Transceiver and the link partner. If the LXT9785E Transceiver establishes link but the software has not read the Non-Phone Detected bit, the Non-Phone Detected bit is cleared anyway once link is established.

If the LXT9785E Transceiver does not establish link within the Link Fail Inhibit Timer period and the software does not read the Non-Phone Detected bit, the Link Fail Time Out bit is set to inform software that a potential link partner other than a phone has been detected, but link cannot be established for some reason. There is no guarantee as to the current state of the connection or LXT9785E Transceiver status under this condition. Register 27 must be read again to determine the current system status.

DTE Discovery Enabled (Dis_En)	27.6 = 1
DTE Discovered (DTE_Dis)	27.4 = 0
Non-Phone Detected (NP_Det)	27.3 = 1
Link Fail Time Out (LFIT_IND)	27.2 = 1

Example 5 Link Partner — Cortina PHY with DTE Discovery Enabled

The system software polls Register 27 to determine if or when a phone is detected. Once the link partner has been connected to the switch, the negotiation process begins. The receiver monitors the next pages to determine that the exact next page data transmitted is received. In this case, the next pages do not match and the LXT9785E Transceiver sets the Non-Phone Detected bit to indicate that a non-phone has been detected.

DTE Discovery Enabled (Dis_En)	27.6 = 1
DTE Discovered (DTE_Dis)	27.4 = 0
Non-Phone Detected (NP_Det)	27.3 = 1
Link Fail Time Out (LFIT_IND)	27.2 = 0

The software, upon detecting that the Non-Phone Detected bit is set (the bit is cleared on read), can change the negotiation status of the LXT9785E Transceiver or allow the LXT9785E Transceiver to continue in auto-negotiation mode. The LXT9785E Transceiver will continue with auto-negotiation with the advertised modes until either the software has changed the negotiation status or link is established.

DTE Discovery Enabled (Dis_En)	27.6 = 1
DTE Discovered (DTE_Dis)	27.4 = 0
Non-Phone Detected (NP_Det)	27.3 = 0
Link Fail Time Out (LFIT_IND)	27.2 = 0

The negotiation process establishes link if a compatible mode exists between the LXT9785E Transceiver and the link partner. If the LXT9785E Transceiver establishes link but the software has not read the Non-Phone Detected bit, the Non-Phone Detected bit is cleared anyway once link is established.

If the LXT9785E Transceiver does not establish link within the Link Fail Inhibit Timer and the software does not read the Non-Phone Detected bit, the Link Fail Time Out bit is set to inform software that a potential link partner other than a phone has been detected, but link cannot be established for some reason. There is no guarantee as to the current state of the connection or LXT9785E Transceiver status under this condition. Register 27 must be read again to determine the current system status.

DTE Discovery Enabled (Dis_En)	27.6 = 1
DTE Discovered (DTE_Dis)	27.4 = 0
Non-Phone Detected (NP_Det)	27.3 = 1
Link Fail Time Out (LFIT_IND)	27.2 = 1

Example 6 Link Partner — Non-Cortina PHY with DTE Discovery Enabled

System software polls Register 27 to determine if or when a phone is detected. The receiver monitors the line to determine if NLPs, MLT3 data, or FLP bursts are being received. The receive activity is FLP bursts, however the data is invalid either for an invalid number of pulses per burst or because the data is different burst-to-burst. The switch PHY detects the FLP bursts transmitted by the LXT9785E Transceiver and switches to transmission of its base page. The new receive activity is again FLP bursts, therefore the status of the next page ability bit is checked. The detected “link partner” does not support next page. The LXT9785E Transceiver transmits the base page and monitors the received base pages for compatibility to try to establish link. The Non-Phone Detected bit is set to indicate that a non-phone has been detected.

DTE Discovery Enabled (Dis_En)	27.6 = 1
DTE Discovered (DTE_Dis)	27.4 = 0
Non-Phone Detected (NP_Det)	27.3 = 1
Link Fail Time Out (LFIT_IND)	27.2 = 0

The software, upon detecting that the Non-Phone Detected bit is set (the bit is cleared on read), can change the negotiation status of the LXT9785E Transceiver or allow the LXT9785E Transceiver to continue in parallel detection. The LXT9785E Transceiver will continue with parallel detection with the advertised modes until either the software has changed the negotiation status or link is established.

DTE Discovery Enabled (Dis_En)	27.6 = 1
DTE Discovered (DTE_Dis)	27.4 = 0
Non-Phone Detected (NP_Det)	27.3 = 0
Link Fail Time Out (LFIT_IND)	27.2 = 0

The negotiation process establishes link if a compatible mode exists between the LXT9785E Transceiver and the link partner. If the LXT9785E Transceiver establishes link but the software has not read the Non-Phone Detected bit, the Non-Phone Detected bit is cleared anyway once link is established.

If the LXT9785E Transceiver does not establish link within the Link Fail Inhibit Timer and the software does not read the Non-Phone Detected bit, the Link Fail Time Out bit is set to inform software that a potential link partner other than a phone has been detected, but link cannot be established for some reason. There is no guarantee as to the current state of the connection or LXT9785E Transceiver status under this condition. Register 27 must be read again to determine the current system status.

DTE Discovery Enabled (Dis_En)	27.6 = 1
DTE Discovered (DTE_Dis)	27.4 = 0
Non-Phone Detected (NP_Det)	27.3 = 1
Link Fail Time Out (LFIT_IND)	27.2 = 1

Example 7 Link Partner — Loop-Back Cable or Token Ring Balun

System software polls Register 27 to determine if or when a phone is detected. Once the link partner has been connected to the switch, the negotiation process begins. The receiver monitors the next pages to determine that the exact next page data transmitted is received. They do match in this case and the LXT9785E Transceiver sets the DTE_Dis bit (27.4) because a *potential* IP phone is detected as the link partner:

DTE Discovery Enabled (Dis_En)	27.6 = 1
DTE Discovered (DTE_Dis)	27.4 = 1
Non-Phone Detected (NP_Det)	27.3 = 0
Link Fail Time Out (LFIT_IND)	27.2 = 0

The software should be written so that the negotiation is not restarted until the potential phone is powered up. The DTE_Dis bit (27.4) is cleared upon restarting or disabling auto-negotiation (selecting forced mode). Since the link partner is not an IP phone in this case, the system must detect an over-current condition and disable power on the cable.

4.0 Summary

After reading this document, the reader should understand the lifeline service and cost reduction benefits of DTE discovery and remote power capabilities in an IP Telephony network. These features are easy to implement and available today using Cortina Ethernet transceivers currently on the market. This document describes the circuitry and software required to implement DTE discovery and remote powering in a VoIP-enabled switch using the LXT9785E Transceiver. It includes detailed examples of software flows required for various link partners when the LXT9785E Transceiver DTE Discovery feature is enabled. It also covers the components and circuitry required in an IP telephone capable of being powered through a data cable. Additional product specifications and design recommendations can be found in the documents listed in [Section 4.1, References, on page 20](#). If you are interested in learning more about IP Telephony, DTE discovery, or Cortina products, contact your local Cortina representative.

4.1 References

For more information on the products or technology covered in this application note, please contact your local Cortina sales office. The following documents are relevant to designing networking equipment for IP Telephony:

Cortina Systems® LXT9785E enhanced 10/100 Octal Transceiver

- LXT9785/LXT9785E Transceiver Datasheet
- LXT9785/LXT9785E Transceiver Specification Update
- LXT9785E Transceiver Design and Layout Guide

Cortina Systems® LXT973 Dual-Port Transceiver

- LXT973 Datasheet
- LXT973 Specification Update
- LXT973 Design and Layout Guide

IP Telephony

- Cortina Solutions for IP Telephony Application Brief
- IP Telephony and DTE Discovery using Cortina Systems® Ethernet PHYs application note (this document)



For additional product and ordering information:

www.cortina-systems.com